

M16 圆形连接器 ROUND PLUG CONNECTOR

直头系列 (带屏蔽环) Straight version (Version with shield clamping ring)

- 1、按照顺序将电缆穿入：压紧螺丝、夹紧圈、密封圈、外壳和第一个屏蔽夹紧环。
- 2、剥线，打开屏蔽层并套入第二个屏蔽夹紧环。
- 3、焊接导线，解开远端衬套，挤压两个屏蔽夹紧环并切断多余屏蔽。
- 4、根据图片安装其他部分。

1. Bead pressing screw, pinch ring, seal, distance shell and first shield clamping ring on cable.
2. Strip wires, widen shield and bead second shield clamping ring.
3. Solder wires, snap distance shell, push the two shield clamping rings together and cutt off projecting shielding braid.
4. Assemble remaining parts according to pictre.

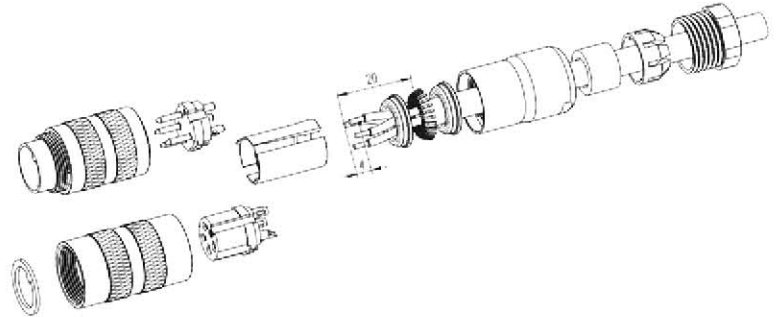

弯角系列 Angled version

- 1、安装密封圈 (3个)
- 2、排列电缆部件
- 3、打电电缆和屏蔽圈
- 4、将导线穿过外壳
- 5、安装屏蔽圈和加紧圈
- 6、将压紧螺丝旋转少许
- 7、将导线焊接于插头上
- 8、在转角位置安装扭矩承载套筒
- 9、安装插头和外壳
- 10、安装保护盖
- 11、用 10-12Nm 的力量拧紧压紧螺丝

- 1.Assembly of seal (3x).
- 2.Bead cable parts.
- 3.Dismantle cable and shield broid.
- 4.Push single wires through the housing.
- 5.Mount shielding ring and pinch ring.
- 6.Slightly fix pressing screw.
- 7.Solder wires to insert.
- 8.Mount positioning sleeve in angled position.
- 9.Put in insert and distance sleeve.
- 10.Mount lid.
- 11.Fis pressing screw (approx. 10-20Nm).

