

彩锌线夹 CABLE CLAMPER

| 名称 Identification | 电缆直径 ϕ (mm) Clamp range | 尺寸 Designation B H | | 型号 Type | 订货号 Part No. |
|---|--|-----------------------|-----|---------|--------------|
| 单层彩锌线夹 1 cable clamper 适配 SCR40 或 ACR30 导轨  | 6-12 | 21 | 23 | K12 | 63312112 |
| | 12-18 | 22.5 | 65 | K18 | 63318118 |
| | 18-22 | 27 | 70 | K22 | 63322122 |
| | 22-30 | 39 | 85 | K30 | 63330130 |
| | 30-38 | 45 | 90 | K38 | 63338138 |
| | 38-42 | 47 | 95 | K42 | 63342142 |
| | 42-50 | 57 | 120 | K50 | 63350150 |
| | 50-64 | 70 | 130 | K64 | 63364164 |
| 双层彩锌线夹 2 cable clamper 适配 SCR40 或 ACR30 导轨  | 6-12 | 16 | 75 | K12.2 | 63312212 |
| | 12-14 | 18 | 77 | K14.2 | 63314214 |
| | 14-16 | 20 | 81 | K16.2 | 63316216 |
| | 16-18 | 22 | 88 | K18.2 | 63318218 |
| | 18-20 | 24 | 90 | K20.2 | 63320220 |
| | 20-22 | 26 | 95 | K22.2 | 63322222 |
| | 22-26 | 30 | 104 | K26.2 | 63326226 |
| | 26-30 | 34 | 122 | K30.2 | 63330230 |
| | 30-34 | 38 | 130 | K34.2 | 63334234 |
| | 三层彩锌线夹 3 cable clamper 适配 SCR40 或 ACR30 导轨  | 6-12 | 16 | 105 | K12.3 |
| 12-14 | | 18 | 107 | K14.3 | 63314314 |
| 14-16 | | 20 | 109 | K16.3 | 63316316 |
| 16-18 | | 22 | 113 | K18.3 | 63318318 |
| 18-20 | | 24 | 117 | K20.3 | 63320320 |
| 20-22 | | 26 | 125 | K22.3 | 63322322 |

| 名称 Identification | 适配导轨 Rail adaptor system | 型号 Type | 订货号 Part No. |
|--|--------------------------|---------|--------------|
| 导轨 Rails  | 钢导轨 Steel rail | SCR40 | 63540000 |
| | 铝导轨 Aluminum rail | ACR30 | 63530000 |

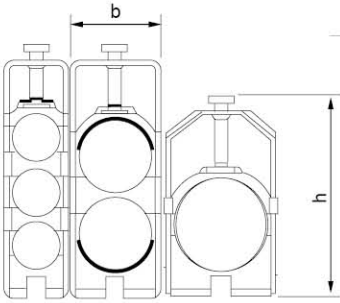

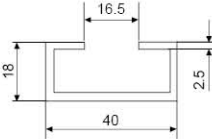

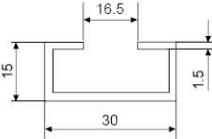

SCR40



ACR30

电磁屏蔽电缆夹 EMC CLAMPING YOKES

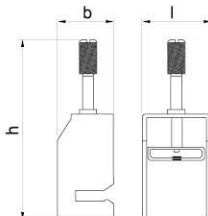

| 名称 Identification | 型号 Type | 订货号 Part No. | 屏蔽电缆直径 Shield diameter | 尺寸 Designation L×B×H (mm) | |
|--|---|--------------|------------------------|---------------------------|----------|
| SK EMC Shield clamps 电磁屏蔽电缆夹 – 弹片式 适配 SCR28 导轨    | SK 3-8 | 63403081 | 3-8mm | 18×14×26 | |
| | SK 4-13.5 | 63404131 | 4-13.5mm | 20×20×31 | |
| | SK 10-20 | 63410201 | 10-20mm | 26×24×40 | |
| | SK 15-32 | 63415321 | 15-32mm | 32×35×64 | |
| | SKF EMC Shield clamps 电磁屏蔽电缆夹 – 弹片式 适配 ACR35 导轨   | SKF 3-8 | 63403082 | 3-8mm | 18×14×26 |
| | | SKF 4-13.5 | 63404132 | 4-13.5mm | 20×20×31 |
| SKF 10-20 | | 63410202 | 10-20mm | 26×24×40 | |
| SKS EMC Shield clamps 电磁屏蔽电缆夹 – 汇流排式 适配 ACR10 导轨   | SKS 1-6 | 63401065 | 1.5-6.5mm | 11×25×30 | |
| | SKS 5-11 | 63405115 | 5-11mm | 17×25×36 | |
| | SKS 10-17 | 63410175 | 10-17mm | 24×25×46 | |

| 名称 Identification | 型号 Type | 订货号 Part No. | 线径 Wire diameter | 尺寸 Designation L x B x H (mm) |
|--|-----------|--------------|------------------|-------------------------------|
| EMC Shield clamps EMC 屏蔽接地端子 适配 ACR10 导轨   | SKH 2-5 | 63702054 | 2 - 5 mm | 9 x 19.5 x 47 |
| | SKH 3-8 | 63703084 | 3 - 8 mm | 12 x 19.5 x 49 |
| | SKH 3-14 | 63703144 | 3 - 14 mm | 17.5 x 19.5 x 60 |
| | SKH 3-20 | 63703204 | 3 - 20 mm | 24.5 x 19.5 x 75 |
| | SKH 5-28 | 63705284 | 5 - 28 mm | 31 x 20 x 93 |
| | SKH 20-35 | 63720354 | 20 - 35 mm | 41 x 20 x 107 |

材料 Material: 钢, 镀锌 Steel, galvanically zinc-plated