

# D-SUB 连接器

## Materials and Platings



Series	FL
Insulator	black thermoplastic, glass filled, (UL94V-0)
Relative temperature index according to UL 74 B	115 °C ( 239 °F)
Heat deflection temperature limit according to DIN 53461 HDT/A	185 °C ( 365°F)
Sub temperature limit	-55 °C ( -67°F)
Shell	Steel
Shell plating (standard)	yellow chromate over zinc plating, pin connector shell without dimples Not RoHS compliant!

## Mechanical Data

Mating force per signal contact	≤ 3.4 N
Unmating force per signal contact	≥ 0.2 N
Maximum sized suitable cable outer diameter	ø 2.2mm (ø 0.087")

## Electrical Data

Current rating	5 A
Test voltage between 2 contacts / shell and contact	1200 V / 1 min
Meets transitional resistance requirements per contact pair in accordance with:	
_ MIL-C- 2430 / MIL-C- 24308	≤ 7.3 mΩ
_ DIN 41652 / DIN 41652	≤ 10 mΩ
Insulation resistance between contacts	≥ 5000 MΩ
Volume resistivity (ASTM-D 257)	10 <sup>16</sup> Ω cm
Dielectric strength	50 kV / mm

工具 Tool		型号 Form	订货号 Part No.
	信号插针压线钳 The signal pin wire clamp	CPT-S	999991
	退针器 Removal tool	REMOV-D-SUB	600002004

# D-SUB 9/15 Pin 连接器

屏蔽 Shielded  
 压接或焊接  
 Crimp / solder pins  
 壳体规格 Size: Size1

插针 Male  
 180°

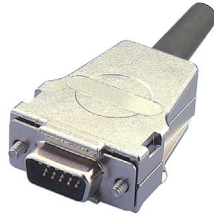

插孔 Female  
 180°



1	型号 Form 焊接式 Solder	900009	900315	901009	901315
	压接式 Crimp	900109		902009	
	极数 Suppression	9-pole	15-pole	9-pole	15-pole
	电路图 Circuit diagram	插针 Male 9 Pin 	插针 Male 15 Pin 	插孔 Female 9 Pin 	插孔 Female 15 Pin 
	压线范围 Wire diameter	6...8.7 mm			

2	技术参数 Technical data	
	额定电压 Supply voltage	30V AC/DC
	额定电流 Current per contact (40°C)	2A
	温度范围 Temperature range	- 25...+ 85 °C
	压线方式 Wiring method	冷压压接 (冷压针见下表) Crimp terminal

## 针 Crimp contacts

### 技术参数 Technical data

材质 Material: 铜镀银/金  
 Copper alloy silver/gold-plated  
 接触电阻 Contact resistance: ≤ 4 mΩ  
 接线形式 Terminal: 冷压接线 Crimp terminal

### 冲压针 Stamped Contacts

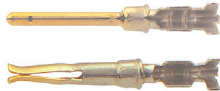

### 车针 Machined Contacts

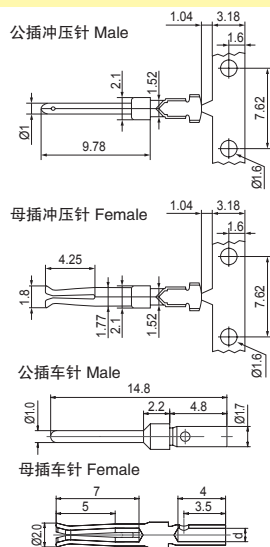

线径 Wire	AWG	冲压针 Stamped Contacts (500 pieces / 卷 reel)		车针 Machined Contacts (100 pieces / 包 pu)	
		型号 Form	订货号 Part No.	型号 Form	订货号 Part No.
0.09-0.25mm <sup>2</sup>	26-22	SAM-13	3 67 000 7167	DAM-13	3 67 000 5576
0.25-0.56mm <sup>2</sup>	22-20	SAM-33	3 67 000 8167	DAM-33	3 67 000 8576
0.09-0.25mm <sup>2</sup>	26-22	SAF-13	3 67 000 7267	DAF-13	3 67 000 5476
0.25-0.56mm <sup>2</sup>	22-20	SAF-33	3 67 000 8267	DAF-33	3 67 000 8476

备注 Notes

# D-SUB 9/15 Pin 连接器

屏蔽 Shielded  
 压接或焊接  
 Crimp / solder pins  
 壳体规格 Size: Size1G

插针 Male  
 45°



插孔 Female  
 45°

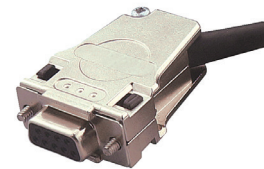

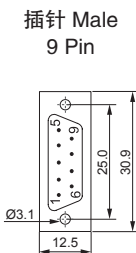
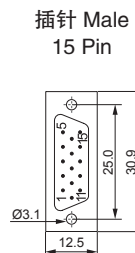
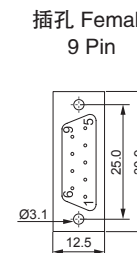
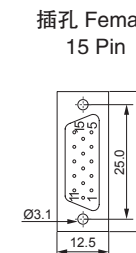
1	型号 Form 焊接式 Solder	910009	910315	911009	911315
	压接式 Crimp	910109		912009	
	极数 Suppression	9-pole	15-pole	9-pole	15-pole
	电路图 Circuit diagram				
	压线范围 Wire diameter	6...8.7 mm			

2	技术参数 Technical data
	额定电压 Supply voltage: 30V AC/DC
	额定电流 Current per contact (40°C): 2A
	温度范围 Temperature range: - 25...+ 85 °C
	压线方式 Wiring method: 冷压压接 (冷压针见下表) Crimp terminal

## 针 Crimp contacts

### 技术参数 Technical data

材质 Material: 铜镀银 / 金

Copper alloy silver/gold-plated

接触电阻 Contact resistance: ≤ 4 mΩ

接线形式 Terminal: 冷压接线 Crimp terminal

### 冲压针 Stamped Contacts

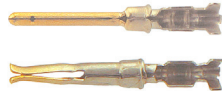

### 车针 Machined Contacts

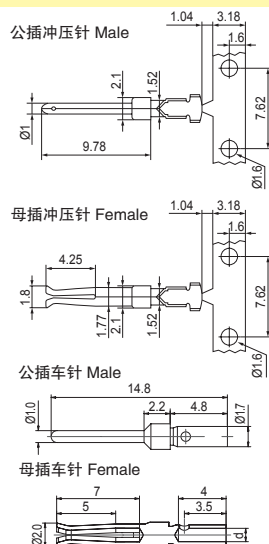

线径 Wire	AWG	冲压针 Stamped Contacts (500 pieces / 卷 reel)		车针 Machined Contacts (100 pieces / 包 pu)	
		型号 Form	订货号 Part No.	型号 Form	订货号 Part No.
0.09-0.25mm <sup>2</sup>	26-22	SAM-13	3 67 000 7167	DAM-13	3 67 000 5576
0.25-0.56mm <sup>2</sup>	22-20	SAM-33	3 67 000 8167	DAM-33	3 67 000 8576
0.09-0.25mm <sup>2</sup>	26-22	SAF-13	3 67 000 7267	DAF-13	3 67 000 5476
0.25-0.56mm <sup>2</sup>	22-20	SAF-33	3 67 000 8267	DAF-33	3 67 000 8476

备注 Notes
----------

# D-SUB 15/26 Pin 连接器

屏蔽 Shielded  
 压接或焊接  
 Crimp / solder pins  
 壳体规格 Size: Size2

插针 Male  
 180°

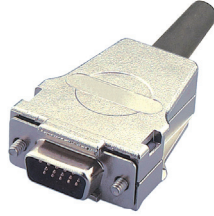

插孔 Female  
 180°



D-SUB 连接器

1	型号 Form 焊接式 Solder	900015	900026	901015	901026
	压接式 Crimp	900115		902015	
	极数 Suppression	15-pole	26-pole	15-pole	26-pole
	电路图 Circuit diagram	插针 Male 15 Pin 	插针 Male 26 Pin 	插孔 Female 15 Pin 	插孔 Female 26 Pin 
	压线范围 Wire diameter	8...11mm			

2	技术参数 Technical data	
	额定电压 Supply voltage	30V AC/DC
	额定电流 Current per contact (40°C)	2A
	温度范围 Temperature range	- 25...+ 85 °C
	压线方式 Wiring method	冷压压接 (冷压针见下表) Crimp terminal

## 针 Crimp contacts

技术参数 Technical data  
 材质 Material: 铜镀银 / 金  
 Copper alloy silver/gold-plated  
 接触电阻 Contact resistance: ≤ 4 mΩ  
 接线形式 Terminal: 冷压接线 Crimp terminal

### 冲压针 Stamped Contacts

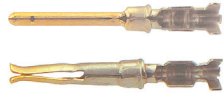

### 车针 Machined Contacts

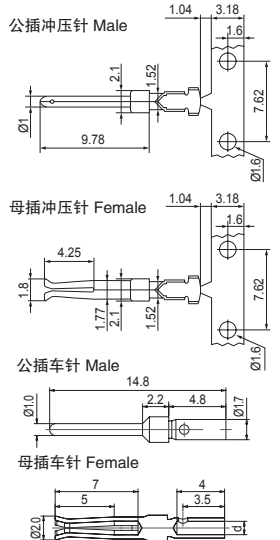

线径 Wire	AWG	冲压针 Stamped Contacts (500 pieces / 卷 reel)		车针 Machined Contacts (100 pieces / 包 pu)	
		型号 Form	订货号 Part No.	型号 Form	订货号 Part No.
0.09-0.25mm <sup>2</sup>	26-22	SAM-13	3 67 000 7167	DAM-13	3 67 000 5576
0.25-0.56mm <sup>2</sup>	22-20	SAM-33	3 67 000 8167	DAM-33	3 67 000 8576
0.09-0.25mm <sup>2</sup>	26-22	SAF-13	3 67 000 7267	DAF-13	3 67 000 5476
0.25-0.56mm <sup>2</sup>	22-20	SAF-33	3 67 000 8267	DAF-33	3 67 000 8476

备注 Notes

# D-SUB 15/26 Pin 连接器



屏蔽 Shielded  
 压接或焊接  
 Crimp / solder pins  
 壳体规格 Size: Size2G



插针 Male  
 45°

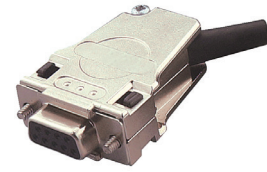

插孔 Female  
 45°

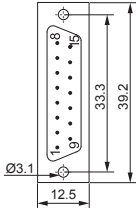
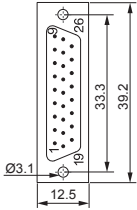
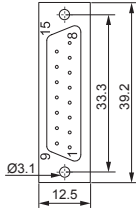
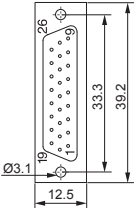
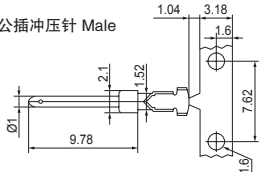
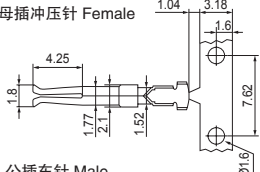
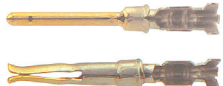
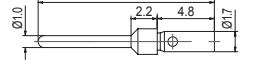
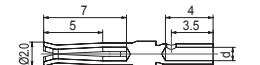

D-SUB 连接器

1	型号 Form 焊接式 Solder	910015	910026	911015	911026																																		
	压接式 Crimp	910115		912015																																			
	极数 Suppression	15-pole	26-pole	15-pole	26-pole																																		
	电路图 Circuit diagram	插针 Male 15 Pin 	插针 Male 26 Pin 	插孔 Female 15 Pin 	插孔 Female 26 Pin 																																		
	压线范围 Wire diameter	8...11mm																																					
2	技术参数 Technical data																																						
	额定电压 Supply voltage 额定电流 Current per contact (40°C) 温度范围 Temperature range 压线方式 Wiring method	30V AC/DC 2A - 25...+ 85 °C 冷压压接 (冷压针见下表) Crimp terminal																																					
	针 Crimp contacts																																						
	技术参数 Technical data 材质 Material: 铜镀银/金 Copper alloy silver/gold-plated 接触电阻 Contact resistance: ≤ 4 mΩ 接线形式 Terminal: 冷压接线 Crimp terminal	公插冲压针 Male 	<table border="1"> <thead> <tr> <th rowspan="2">线径 Wire</th> <th rowspan="2">AWG</th> <th colspan="2">冲压针 Stamped Contacts (500 pieces / 卷 reel)</th> <th colspan="2">车针 Machined Contacts (100 pieces / 包 pu)</th> </tr> <tr> <th>型号 Form</th> <th>订货号 Part No.</th> <th>型号 Form</th> <th>订货号 Part No.</th> </tr> </thead> <tbody> <tr> <td>0.09-0.25mm<sup>2</sup></td> <td>26-22</td> <td>SAM-13</td> <td>3 67 000 7167</td> <td>DAM-13</td> <td>3 67 000 5576</td> </tr> <tr> <td>0.25-0.56mm<sup>2</sup></td> <td>22-20</td> <td>SAM-33</td> <td>3 67 000 8167</td> <td>DAM-33</td> <td>3 67 000 8576</td> </tr> <tr> <td>0.09-0.25mm<sup>2</sup></td> <td>26-22</td> <td>SAF-13</td> <td>3 67 000 7267</td> <td>DAF-13</td> <td>3 67 000 5476</td> </tr> <tr> <td>0.25-0.56mm<sup>2</sup></td> <td>22-20</td> <td>SAF-33</td> <td>3 67 000 8267</td> <td>DAF-33</td> <td>3 67 000 8476</td> </tr> </tbody> </table>		线径 Wire	AWG	冲压针 Stamped Contacts (500 pieces / 卷 reel)		车针 Machined Contacts (100 pieces / 包 pu)		型号 Form	订货号 Part No.	型号 Form	订货号 Part No.	0.09-0.25mm <sup>2</sup>	26-22	SAM-13	3 67 000 7167	DAM-13	3 67 000 5576	0.25-0.56mm <sup>2</sup>	22-20	SAM-33	3 67 000 8167	DAM-33	3 67 000 8576	0.09-0.25mm <sup>2</sup>	26-22	SAF-13	3 67 000 7267	DAF-13	3 67 000 5476	0.25-0.56mm <sup>2</sup>	22-20	SAF-33	3 67 000 8267	DAF-33	3 67 000 8476	母插冲压针 Female 
线径 Wire	AWG	冲压针 Stamped Contacts (500 pieces / 卷 reel)		车针 Machined Contacts (100 pieces / 包 pu)																																			
		型号 Form	订货号 Part No.	型号 Form	订货号 Part No.																																		
0.09-0.25mm <sup>2</sup>	26-22	SAM-13	3 67 000 7167	DAM-13	3 67 000 5576																																		
0.25-0.56mm <sup>2</sup>	22-20	SAM-33	3 67 000 8167	DAM-33	3 67 000 8576																																		
0.09-0.25mm <sup>2</sup>	26-22	SAF-13	3 67 000 7267	DAF-13	3 67 000 5476																																		
0.25-0.56mm <sup>2</sup>	22-20	SAF-33	3 67 000 8267	DAF-33	3 67 000 8476																																		
	冲压针 Stamped Contacts 	公插车针 Male 			母插车针 Female 																																		
	车针 Machined Contacts 																																						
	备注 Notes																																						

# D-SUB 25/44 Pin 连接器

屏蔽 Shielded  
 压接或焊接  
 Crimp / solder pins  
 壳体规格 Size: Size3

插针 Male  
 180°



插孔 Female  
 180°



1	型号 Form 焊接式 Solder	900025	901025
	压接式 Crimp	900125	902025
	极数 Suppression	25-pole	25-pole
	电路图 Circuit diagram	<p>插针 Male 25 Pin</p>	<p>插孔 Female 25 Pin</p>
	压线范围 Wire diameter	8...11mm	

2	技术参数 Technical data	
	额定电压 Supply voltage	30V AC/DC
	额定电流 Current per contact (40°C)	2A
	温度范围 Temperature range	- 25...+ 85 °C
	压线方式 Wiring method	冷压压接 (冷压针见下表) Crimp terminal

## 针 Crimp contacts

技术参数 Technical data  
 材质 Material: 铜镀银 / 金  
 Copper alloy silver/gold-plated  
 接触电阻 Contact resistance: ≤ 4 mΩ  
 接线形式 Terminal: 冷压接线 Crimp terminal

### 冲压针 Stamped Contacts

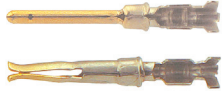

### 车针 Machined Contacts

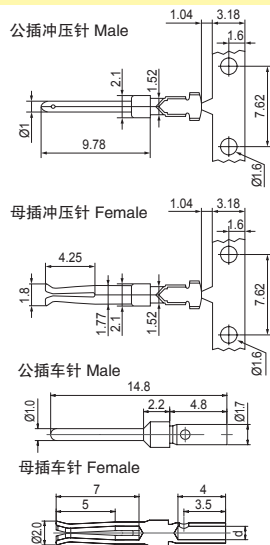

线径 Wire	AWG	冲压针 Stamped Contacts (500 pieces / 卷 reel)		车针 Machined Contacts (100 pieces / 包 pu)	
		型号 Form	订货号 Part No.	型号 Form	订货号 Part No.
0.09-0.25mm <sup>2</sup>	26-22	SAM-13	3 67 000 7167	DAM-13	3 67 000 5576
0.25-0.56mm <sup>2</sup>	22-20	SAM-33	3 67 000 8167	DAM-33	3 67 000 8576
0.09-0.25mm <sup>2</sup>	26-22	SAF-13	3 67 000 7267	DAF-13	3 67 000 5476
0.25-0.56mm <sup>2</sup>	22-20	SAF-33	3 67 000 8267	DAF-33	3 67 000 8476

备注 Notes

# D-SUB 25/44 Pin 连接器

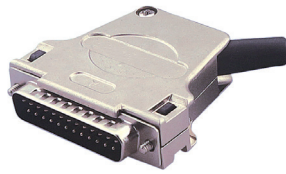

屏蔽 Shielded  
 压接或焊接  
 Crimp / solder pins  
 壳体规格 Size: Size3G

插针 Male  
 45°

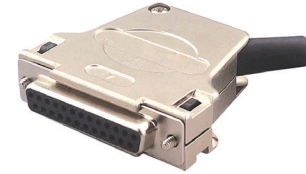

插孔 Female  
 45°

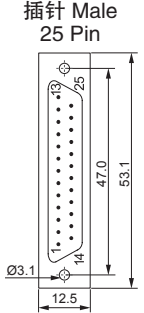
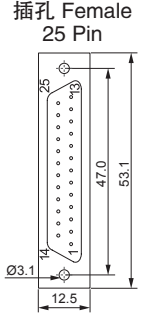
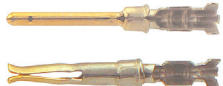
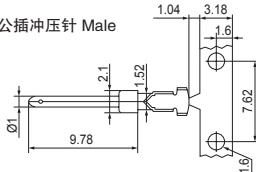

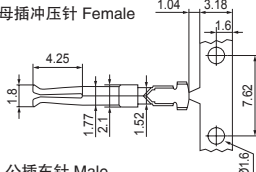
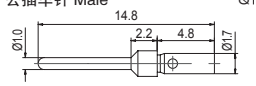
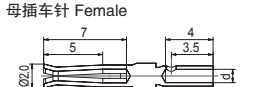
1	型号 Form 焊接式 Solder	910025	911025																																		
	压接式 Crimp	910125	912025																																		
极数 Suppression		25-pole	25-pole																																		
电路图 Circuit diagram		<p>插针 Male 25 Pin</p> 	<p>插孔 Female 25 Pin</p> 																																		
压线范围 Wire diameter		8...11mm																																			
2 技术参数 Technical data																																					
额定电压 Supply voltage		30V AC/DC																																			
额定电流 Current per contact (40°C)		2A																																			
温度范围 Temperature range		- 25...+ 85 °C																																			
压线方式 Wiring method		冷压压接 (冷压针见下表) Crimp terminal																																			
针 Crimp contacts																																					
<p>技术参数 Technical data</p> <p>材质 Material: 铜镀银/金                  Copper alloy silver/gold-plated</p> <p>接触电阻 Contact resistance: ≤ 4 mΩ</p> <p>接线形式 Terminal: 冷压接线 Crimp terminal</p>		<table border="1"> <thead> <tr> <th rowspan="2">线径 Wire</th> <th rowspan="2">AWG</th> <th colspan="2">冲压针 Stamped Contacts (500 pieces / 卷 reel)</th> <th colspan="2">车针 Machined Contacts (100 pieces / 包 pu)</th> </tr> <tr> <th>型号 Form</th> <th>订货号 Part No.</th> <th>型号 Form</th> <th>订货号 Part No.</th> </tr> </thead> <tbody> <tr> <td>0.09-0.25mm<sup>2</sup></td> <td>26-22</td> <td>SAM-13</td> <td>3 67 000 7167</td> <td>DAM-13</td> <td>3 67 000 5576</td> </tr> <tr> <td>0.25-0.56mm<sup>2</sup></td> <td>22-20</td> <td>SAM-33</td> <td>3 67 000 8167</td> <td>DAM-33</td> <td>3 67 000 8576</td> </tr> <tr> <td>0.09-0.25mm<sup>2</sup></td> <td>26-22</td> <td>SAF-13</td> <td>3 67 000 7267</td> <td>DAF-13</td> <td>3 67 000 5476</td> </tr> <tr> <td>0.25-0.56mm<sup>2</sup></td> <td>22-20</td> <td>SAF-33</td> <td>3 67 000 8267</td> <td>DAF-33</td> <td>3 67 000 8476</td> </tr> </tbody> </table>		线径 Wire	AWG	冲压针 Stamped Contacts (500 pieces / 卷 reel)		车针 Machined Contacts (100 pieces / 包 pu)		型号 Form	订货号 Part No.	型号 Form	订货号 Part No.	0.09-0.25mm <sup>2</sup>	26-22	SAM-13	3 67 000 7167	DAM-13	3 67 000 5576	0.25-0.56mm <sup>2</sup>	22-20	SAM-33	3 67 000 8167	DAM-33	3 67 000 8576	0.09-0.25mm <sup>2</sup>	26-22	SAF-13	3 67 000 7267	DAF-13	3 67 000 5476	0.25-0.56mm <sup>2</sup>	22-20	SAF-33	3 67 000 8267	DAF-33	3 67 000 8476
线径 Wire	AWG	冲压针 Stamped Contacts (500 pieces / 卷 reel)				车针 Machined Contacts (100 pieces / 包 pu)																															
		型号 Form	订货号 Part No.	型号 Form	订货号 Part No.																																
0.09-0.25mm <sup>2</sup>	26-22	SAM-13	3 67 000 7167	DAM-13	3 67 000 5576																																
0.25-0.56mm <sup>2</sup>	22-20	SAM-33	3 67 000 8167	DAM-33	3 67 000 8576																																
0.09-0.25mm <sup>2</sup>	26-22	SAF-13	3 67 000 7267	DAF-13	3 67 000 5476																																
0.25-0.56mm <sup>2</sup>	22-20	SAF-33	3 67 000 8267	DAF-33	3 67 000 8476																																
<p>冲压针 Stamped Contacts</p> 		<p>公插冲压针 Male</p> 																																			
<p>车针 Machined Contacts</p> 		<p>母插冲压针 Female</p> 																																			
		<p>公插车针 Male</p> 																																			
		<p>母插车针 Female</p> 																																			
备注 Notes																																					

# D-SUB 连接器外壳

## 45° 出线

D-SUB 连接器

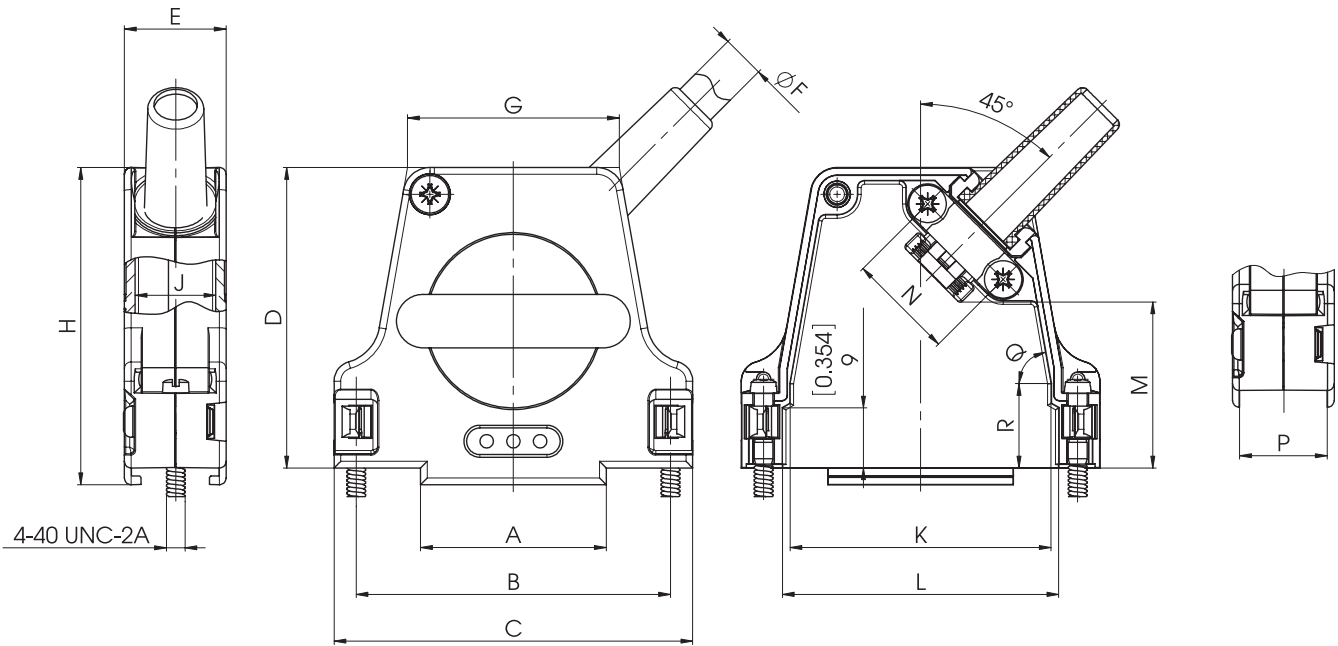

壳体规格 Size	特征 Features	Shell Size/for	A	B	C	D	E	Ø F		G	H	J	K	L	M	N	P	Q	R
								不带橡胶套 Without Rubber Bushing	带橡胶套 With Rubber Bushing max.										
SIZE1		1 / 9	14.9	25.0	31.6	39.5	15.2	3.0 - 9.5	6.5	20.8	42.0	12.1	17.0	19.4	23.0	12.0	13.1		
SIZE2-1		2 / 15	15.9	33.3	40.0	41.0	15.2	3.0 - 8.5	6.5	23.3	43.5	12.1	25.8	27.9	21.0	16.0	13.1	84°	
SIZE2-2	大外径 Large cable outlet	2 / 15	15.9	33.3	40.0	41.0	15.2	8.5 - 12.5	9.0	23.3	43.5	12.1	25.8	27.9	21.0	16.0	13.1	84°	
SIZE3-1		3 / 25	27.8	47.0	53.7	45.0	15.2	3.0 - 8.5	8.0	31.7	47.5	12.1	39.0	41.4	25.0	16.0	13.0	80°	12.9
SIZE3-2	大外径 Large cable outlet	3 / 25	27.8	47.0	53.7	45.0	15.2	8.5 - 12.5	9.0	31.7	47.5	12.1	39.0	41.4	25.0	16.0	13.0	80°	12.9
SIZE4-1		4 / 37	44.3	63.5	70.2	48.0	18.2	3.0 - 12.0	9.0	48.2	50.5	15.1	55.5	57.8	23.2	21.0	12.7	80°	16.1
SIZE4-2	大外径 Large cable outlet	4 / 37	44.3	63.5	70.2	48.0	18.2	12.0 - 15.0	11.5	48.2	50.5	15.1	55.5	57.8	23.2	21.0	12.7	80°	16.1
SIZE5-1		5 / 50	41.9	61.1	67.8	48.0	18.2	3.0 - 12.0	9.7	45.8	50.5	15.1	53.1	55.5	23.2	21.0	15.9	80°	16.1
SIZE5-2	大外径 Large cable outlet	5 / 50	41.9	61.1	67.8	48.0	18.2	12.0 - 15.0	11.5	45.8	50.5	15.1	53.1	55.5	23.2	21.0	15.9	80°	16.1

## 技术参数 Technical data

材质 Material and platings

Zinc die-cast, nickel plated

温度范围 Temperature range

-35°C bis 100°C (-67°F to 212°F)

最大锁紧力 max. torque \*

40 Ncm (0.295 ft.lb.)

\* Not for locking screws



# D-SUB 连接器外壳

## 180° 出线

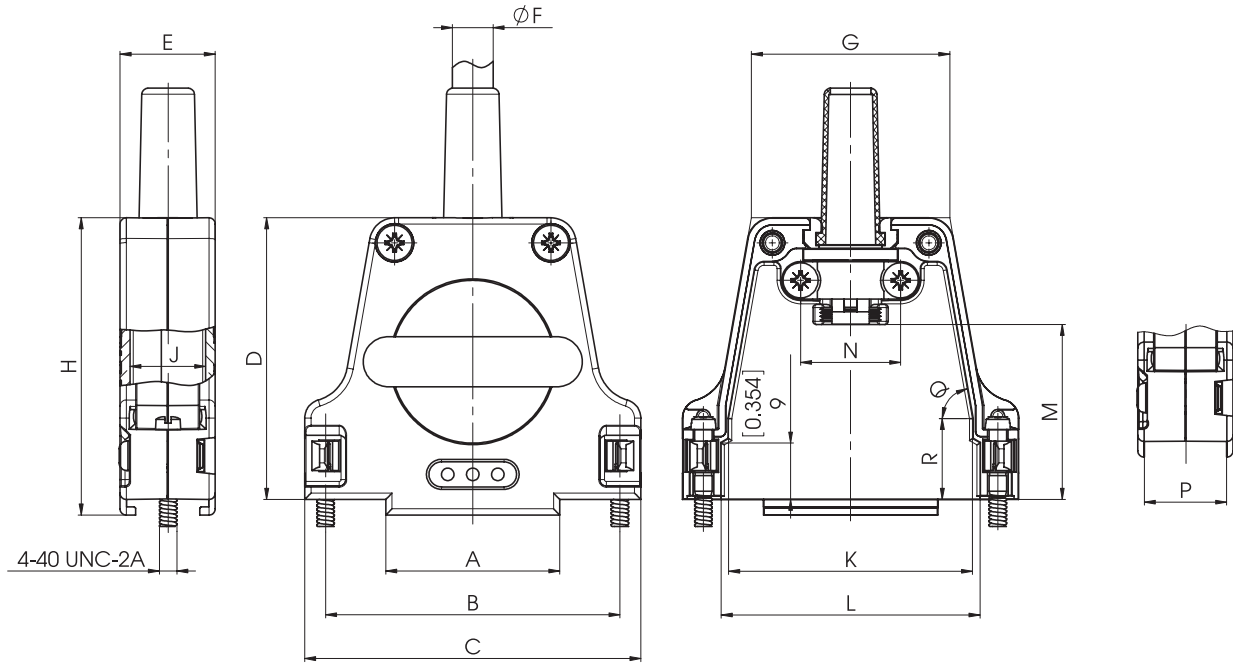

壳体规格 Size	特征 Features	Shell Size/for	A	B	C	D	E	Ø F		G	H	J	K	L	M	N	P	Q	R
								不带橡胶套 Without Rubber Bushing	带橡胶套 With Rubber Bushing max.										
SIZE1G		1 / 9	14.9	25.0	31.6	39.5	15.2	3.0 - 9.5	6.5	20.8	42.0	12.1	17.0	19.4	23.5	12.0	13.1		
SIZE2G-1		2 / 15	15.9	33.3	40.0	41.0	15.2	3.0 - 8.5	6.5	23.3	43.5	12.1	25.8	27.9	19.0	16.0	13.1	84°	
SIZE2G-2	大外径 Large cable outlet	2 / 15	15.9	33.3	40.0	41.0	15.2	8.5 - 12.5	9.0	23.3	43.5	12.1	25.8	27.9	19.0	16.0	13.1	84°	
SIZE3G-1		3 / 25	27.8	47.0	53.7	45.0	15.2	3.0 - 8.5	8.0	31.7	47.5	12.1	39.0	41.4	28.0	16.0	13.1	80°	12.9
SIZE3G-2	大外径 Large cable outlet	3 / 25	27.8	47.0	53.7	45.0	15.2	8.5 - 12.5	9.0	31.7	47.5	12.1	39.0	41.4	28.0	16.0	13.1	80°	12.9
SIZE4G-1		4 / 37	44.3	63.5	70.2	48.0	18.2	3.0 - 12.0	9.0	48.2	50.5	15.1	55.5	57.8	32.5	21.0	12.7	80°	16.1
SIZE4G-2	大外径 Large cable outlet	4 / 37	44.3	63.5	70.2	48.0	18.2	12.0 - 15.0	11.5	48.2	50.5	15.1	55.5	57.8	32.5	21.0	12.7	80°	16.1
SIZE5G-1		5 / 50	41.9	61.1	67.8	48.0	18.2	3.0 - 12.0	9.7	45.8	50.5	15.1	53.1	55.5	32.5	21.0	15.9	80°	16.1
SIZE5G-2	大外径 Large cable outlet	5 / 50	41.9	61.1	67.8	48.0	18.2	12.0 - 15.0	11.5	45.8	50.5	15.1	53.1	55.5	32.5	21.0	15.9	80°	16.1

## 技术参数 Technical data

材质 Material and platings	Zinc die-cast, nickel plated
温度范围 Temperature range	-35°C bis 100°C (-67°F to 212°F)
最大锁紧力 max. torque *	40 Ncm (0.295 ft.lb.)

\* Not for locking screws

# D-SUB 9 Pin 总线连接器

屏蔽 Shielded  
螺钉压接  
With screw terminals

插针 Male  
45°



插孔 Female  
45°



<b>1</b> 型号 Form	955091	955092
极数 Suppression	9-pole	9-pole
电路图 Circuit diagram	<p>插针 Male 9 Pin</p>	<p>插孔 Female 9 Pin</p>
压线范围 Wire diameter	4...10mm	

<b>2</b> 技术参数 Technical data	
额定电压 Supply voltage	50V AC/DC
额定电流 Current per contact (40°C)	1A
温度范围 Temperature range	- 20...+ 75 °C
压线方式 Wiring method	螺钉压接 With screw terminals

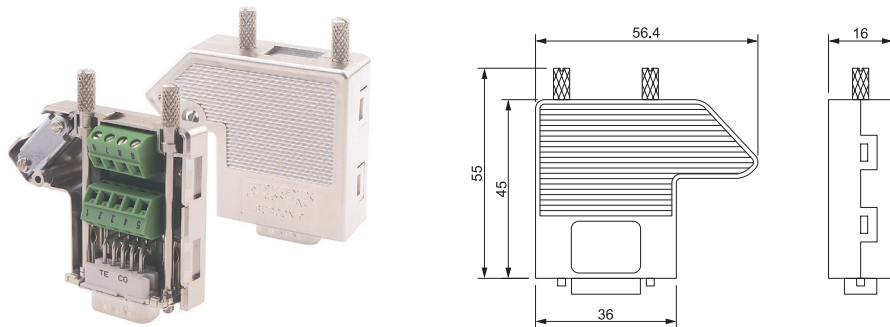

订货号 Part No.



**1** 型号 Form

备注 Notes

# D-SUB 15 Pin 总线连接器

屏蔽 Shielded  
螺钉压接  
With screw terminals

插针 Male  
45°



插孔 Female  
45°

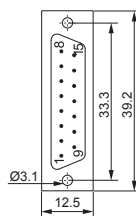
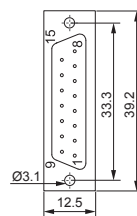
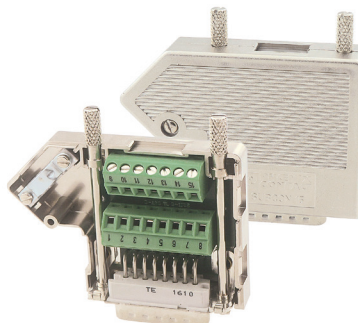
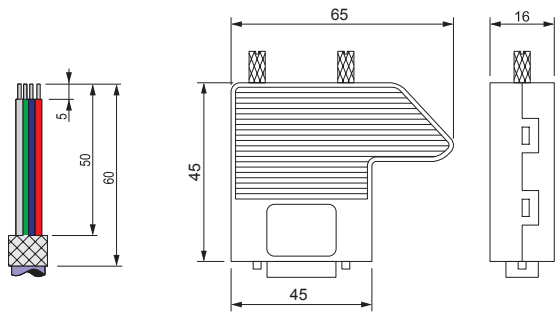

<b>1</b>	<b>型号 Form</b>	<b>955151</b>	<b>955152</b>
	极数 Suppression	15-pole	15-pole
	电路图 Circuit diagram	<p>插针 Male 15 Pin</p> 	<p>插孔 Female 15 Pin</p> 
	压线范围 Wire diameter	4...10mm	
<b>2</b>	<b>技术参数 Technical data</b>		
	额定电压 Supply voltage	50V AC/DC	
	额定电流 Current per contact (40°C)	1A	
	温度范围 Temperature range	- 20...+ 75 °C	
	压线方式 Wiring method	螺钉压接 With screw terminals	
		 	
	<b>订货号 Part No.</b>	<div style="border: 1px solid black; height: 20px; width: 100%;"></div>	
		<div style="border: 1px solid black; height: 20px; width: 100%;"></div>	<div style="border: 1px solid black; height: 20px; width: 100%;"></div>
		<b>1</b>	<b>型号 Form</b>
	<b>备注 Notes</b>		

# D-SUB 25 Pin 总线连接器

屏蔽 Shielded  
螺钉压接  
With screw terminals

插针 Male  
45°



插孔 Female  
45°

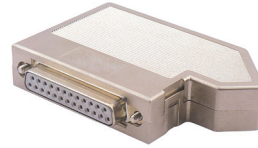

D-SUB 连接器

<b>1</b> 型号 Form	<b>955251</b>	<b>955252</b>
极数 Suppression	25-pole	25-pole
电路图 Circuit diagram	<p>插针 Male 25 Pin</p>	<p>插孔 Female 25 Pin</p>
压线范围 Wire diameter	4...10mm	

<b>2</b> 技术参数 Technical data	
额定电压 Supply voltage	50V AC/DC
额定电流 Current per contact (40°C)	1A
温度范围 Temperature range	- 20...+ 75 °C
压线方式 Wiring method	螺钉压接 With screw terminals

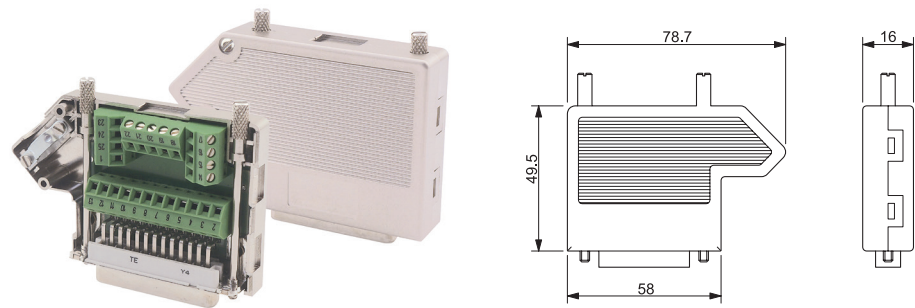

订货号 Part No.		
	<p>----- ----- -----</p>	

**1** 型号 Form

备注 Notes	
----------	--