

EMC 创新产品 CABLE CLAMPER

总览 At a glance

过程测量和控制设备需要越来越高的故障防护能力。要达到这一点，屏蔽以及屏蔽接地是非常重要的。为了使屏蔽层发挥良好的作用，以下两点必不可少：

- 电缆屏蔽层连接大地需要较高的可靠性。
- 连接接触面以及结构要具有极低的阻抗。

By using icotek strain relief systems the user can quickly assemble, organize and provide strain relief for cables.

The systems can be used for organizing and securing cables in machines, switch cabinets, enclosures and dynamic cable carriers.

优势 Benefits

1. 灵活

由于有各种各样型号的 DIN 导轨和螺钉类型的组合，SVLEC 提供了很多安装方式。

2. 快速，无工具安装

直接把电缆接入屏蔽夹就完成安装。

3. 紧紧固定

尺寸合适并配套电缆扎带使用，就能提供符合 VDE 的应力释放。

4. 很大的接触面积

屏蔽接地端子与电缆屏蔽层有很大的接触面积 (如图 A)。与传统的屏蔽接地端子相比，当使用产品的时候我们可以提高 50% 的接触面积，从而降低接触电阻。

5. 大大降低高频干扰

在很宽的频率范围内，屏蔽接地端子能提供很低的阻抗。例如在 1000 MHz 达到 120 Ohms；10 KHz 到 100 MHz，达到 20 Ohms。

1. Flexible

Because of the many different types of DIN rails and screw type assemblies, SVLEC offers numerous mounting options.

2. Fast and easy assembly

Securing the cables is done quickly and inexpensively with standard cable ties.

3. Secure hold

The unique shape of the strain relief securely holds the cable tie and cable.

4. High packing density

The strain relief plates are available in several sizes. By multilayer mounting the packing density can be greatly increased.

5. Flexibility

Due to the wide variety of sizes and designs, a matching product for each application can be found.

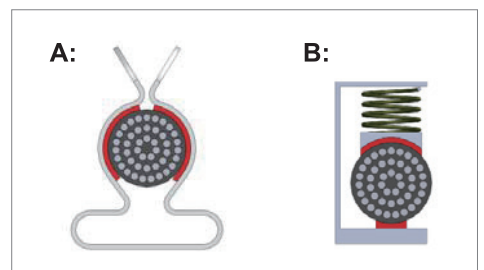

彩锌线夹 CABLE CLAMPER

名称 Identification	电缆直径 ϕ (mm) Clamp range	尺寸 Designation		型号 Type	订货号 Part No.
		B	H		
单层彩锌线夹 1 cable clamper 适配 SCR40 或 ACR30 导轨  SCR40 或 ACR30 导轨	6-12	21	23	K12	63312112
	12-18	22.5	65	K18	63318118
	18-22	27	70	K22	63322122
	22-30	39	85	K30	63330130
	30-38	45	90	K38	63338138
	38-42	47	95	K42	63342142
	42-50	57	120	K50	63350150
	50-64	70	130	K64	63364164
双层彩锌线夹 2 cable clamper 适配 SCR40 或 ACR30 导轨 	6-12	16	75	K12.2	63312212
	12-14	18	77	K14.2	63314214
	14-16	20	81	K16.2	63316216
	16-18	22	88	K18.2	63318218
	18-20	24	90	K20.2	63320220
	20-22	26	95	K22.2	63322222
	22-26	30	104	K26.2	63326226
	26-30	34	122	K30.2	63330230
	30-34	38	130	K34.2	63334234
	三层彩锌线夹 3 cable clamper 适配 SCR40 或 ACR30 导轨 	6-12	16	105	K12.3
12-14		18	107	K14.3	63314314
14-16		20	109	K16.3	63316316
16-18		22	113	K18.3	63318318
18-20		24	117	K20.3	63320320
20-22		26	125	K22.3	63322322

彩锌线夹

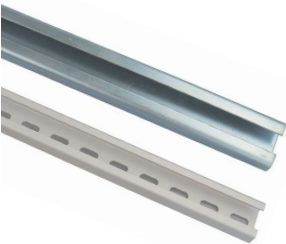
名称 Identification	适配导轨 Rail adaptor system	型号 Type	订货号 Part No.
导轨 Rails 	钢导轨 Steel rail	SCR40	63540000
	铝导轨 Aluminum rail	ACR30	63530000

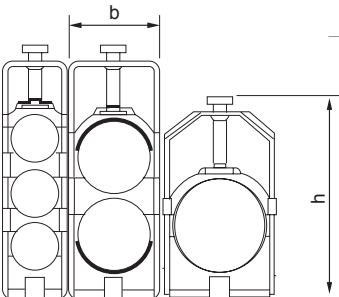

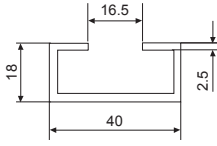

SCR40

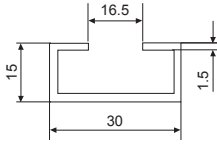

ACR30

电磁屏蔽电缆夹 EMC CLAMPING YOKES

电磁屏蔽电缆夹

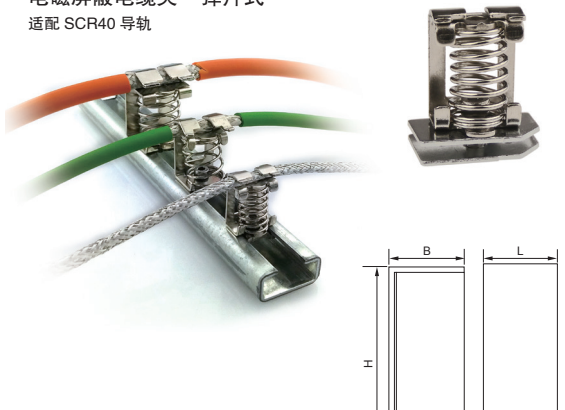
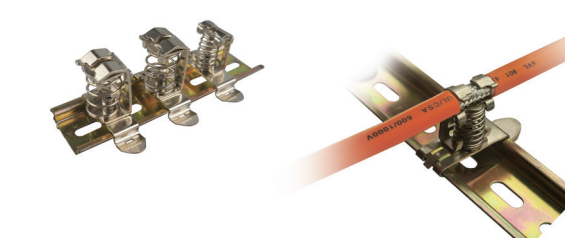
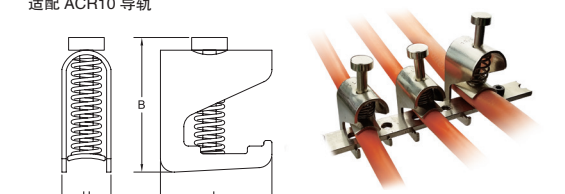
名称 Identification	型号 Type	订货号 Part No.	屏蔽电缆直径 Shield diameter	尺寸 Designation LxBxH (mm)
SK EMC Shield clamps 电磁屏蔽电缆夹 – 弹片式 适配 SCR40 导轨 	SK 3-8	63403081	3-8mm	18x14x26
	SK 4-13.5	63404131	4-13.5mm	20x20x31
	SK 10-20	63410201	10-20mm	26x24x40
	SK 15-32	63415321	15-32mm	32x35x64
SKF EMC Shield clamps 电磁屏蔽电缆夹 – 弹片式 适配 ACR35 导轨 	SKF 3-8	63403082	3-8mm	18x14x26
	SKF 4-13.5	63404132	4-13.5mm	20x20x31
	SKF 10-20	63410202	10-20mm	26x24x40
	SKF 15-32	63415322	15-32mm	32x35x64
SKS EMC Shield clamps 电磁屏蔽电缆夹 – 汇流排式 适配 ACR10 导轨 	SKS 1-6	63401065	1.5-6.5mm	11x25x30
	SKS 5-11	63405115	5-11mm	17x25x36
	SKS 10-17	63410175	10-17mm	24x25x46

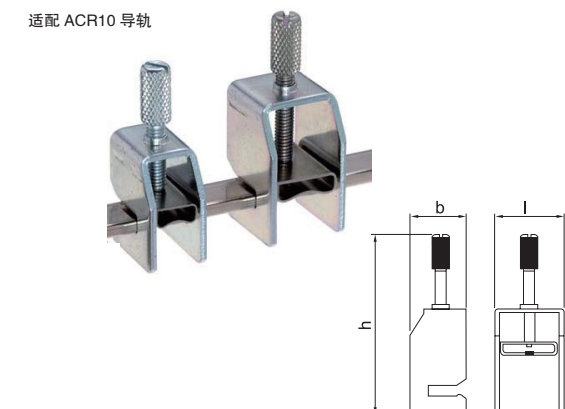
名称 Identification	型号 Type	订货号 Part No.	线径 Wire diameter	尺寸 Designation L x B x H (mm)
EMC Shield clamps EMC 屏蔽接地端子 适配 ACR10 导轨 	SKH 2-5	63702054	2 - 5 mm	9 x 19.5 x 47
	SKH 3-8	63703084	3 - 8 mm	12 x 19.5 x 49
	SKH 3-14	63703144	3 - 14 mm	17.5 x 19.5 x 60
	SKH 3-20	63703204	3 - 20 mm	24.5 x 19.5 x 75
	SKH 5-28	63705284	5 - 28 mm	31 x 20 x 93
	SKH 20-35	63720354	20 - 35 mm	41 x 20 x 107

材料 Material: 钢, 镀锌 Steel, galvanically zinc-plated

电磁屏蔽电缆夹 EMC CLAMPING YOKES

名称 Identification	型号 Type	订货号 Part No.	电缆直径 ϕ (mm) Shield diameter	尺寸 Designation L x W x H (mm)
PSKL 适用于汇流排的接地端子 适配 ACR10 导轨   优势 <ul style="list-style-type: none"> ◆ 电缆屏蔽的最佳接触面积 ◆ 不需要工具的简易组装 ◆ 防震, 无需维护 ◆ 对电缆屏蔽永久、持续的弹压力, 不需要对压力作出调整 规格 SKL-clamp: 弹簧钢, 镀锌 PFK-foot: 弹簧钢 适用汇流排厚度 1.5 - 2 mm	PSKL 1.5-3	63401036	1.5 - 3.0	42 x 13 x 24.5
	PSKL 3 - 6	63403066	3.0 - 6.0	42 x 13 x 24.5
	PSKL 6 - 8	63406086	6.0 - 8.0	42 x 13 x 24.5
	PSKL 8 - 11	63408116	8.0 - 11	42 x 13 x 24.5
DSKL 使用于汇流排的接地端子 (两只) 适配 ACR10 导轨   优势 <ul style="list-style-type: none"> ◆ 电缆屏蔽的最佳接触面积 ◆ 不需要工具的简易组装 ◆ 防震, 无需维护 ◆ 对电缆屏蔽永久、持续的弹压力, 不需要对压力作出调整 ◆ 空间的最优利用 规格 SKL-clamp: 弹簧钢, 镀锌 PFK-foot: 弹簧钢 适用汇流排厚度 1.5 - 2 mm	DSKL 1.5 - 3	63401037	1.5 - 3.0	42 x 13 x 24.5
	DSKL 3 - 6	63403067	3.0 - 6.0	42 x 13 x 24.5
	DSKL 6 - 8	63406087	6.0 - 8.0	42 x 13 x 24.5

名称 Identification	型号 Type	订货号 Part No.	屏蔽电缆直径 Shield diameter
SKL EMC Shield clamps 电磁屏蔽电缆夹——卡口式 适配 ACR35 导轨   卡口式	SKL 3-6	63403064	3-6mm
	SKL 6-8	63406084	6-8mm
	SKL 8-11	63409114	8-12mm
	SKL 12-16	63412164	12-17mm
	SKL 17-22	63417224	17-23mm
	SKL 23-29	63423294	23-29mm
SKL EMC Shield clamps 电磁屏蔽电缆夹——固定式 适配 ACR35 导轨  固定式	ZSKL 3-6	63403068	3-6mm
	ZSKL 6-8	63406088	6-8mm
	ZSKL 8-11	63409118	8-12mm
	ZSKL 12-16	63412168	12-17mm
	ZSKL 17-22	63417228	17-23mm
	ZSKL 23-29	63423298	23-29mm



电缆紧固件 CABLE FASTENERS

名称 Identification	型号 Type	订货号 Part No.	电缆夹子 Number of shield clamps	长度 Length	宽度 Width
EMC 带有应力释放的接地组合 	RSKL (x6)	63400006	6xSKL	88.0 mm	44.4mm

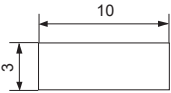

电缆紧固件 Cable fasteners	型号 Type	订货号 Part No.	尺寸 Dimension L x B x H
	MF - A49	63600149	80 x 20 x 49 mm
	MF - B30	63600230	72 x 20 x 30 mm
	MF - B49	63600249	23 x 19 x 19 mm

导轨 Rail

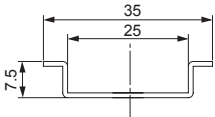
轻型管夹导轨 Light pipe clamp guide rail	型号 Type	订货号 Part No.	包装数量 PU
 	ACR10	99036099	1 米
 	ACR35	99036098	1 米