



兴威联电气
— SVLEC[®] —

SVLEC / 追 / 求 / 卓 / 越 / / 追 / 求 / 精 / 致



M23信号、动力连接器



M40动力连接器

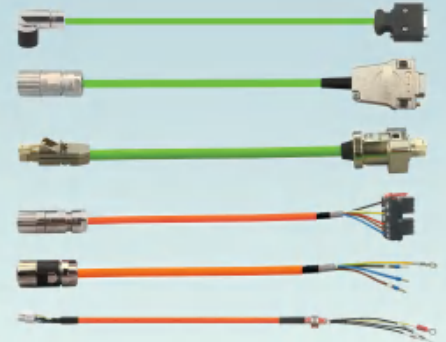

伺服驱动连接线束

伺服线束

SERVO APPLICATIONS

伺服连接器 SERVO CONNECTOR

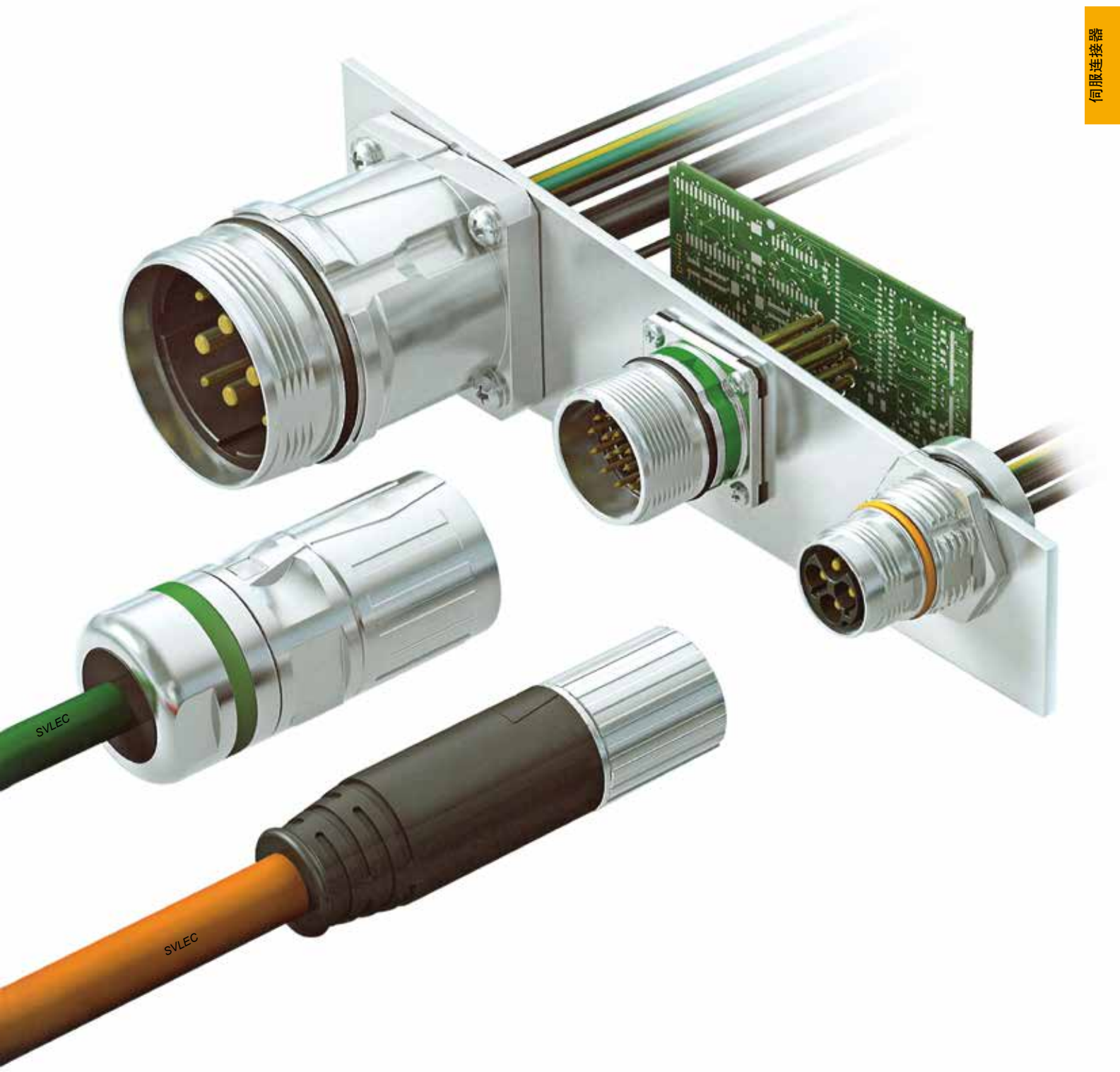

第七章 Chapter 7

M23 M40 连接器 Connect



M23 M40 接头 Connect



伺服线束
Servo applications

- 7.1 M23 信号连接器 Signal connector
- 7.2 M23 动力连接器 Power connector
- 7.3 M40 动力连接器 Power connector
- 7.4 伺服驱动连接动力线束
Servo and power drive systems
- 7.5 伺服驱动连接信号线束
Servo drive connection signal cable
- 7.6 V90 伺服线束 Servo applications

连接器定义形式 CONNECTOR DEFINITION FORM

圆形连接器型号定义 Round plug connectors

RC - M23 - S BS - 12 M - CW - A - F

系列号 Series

规格 Specification

- M23
- M25
- M30
- M40
- M41
- ⋮

类型 Type

- S = 信号 Signal
- P = 动力 Power

出线方式 Terminations technology

- PS = 插头直出 Plug straight
- PR = 插头 Plug 90°
- BS = 插座直出 Socket straight
- BR = 插座 Socket 90°
- CC = 线对线 Cable to cable

极数 Suppression

- 6 针 pole
- 8 针 pole
- 9 针 pole
- 12 针 pole
- 17 针 pole
- 19 针 pole
- ⋮

接口 Interface

- M= 公头 Male
- F= 母头 Female

固定方式 Fixed mode
(仅限于插座)
(not only for socket)

- F = 法兰安装座
Flange installation
- N = 螺母安装座
Nut mounting base
- S = PCB 板焊接
Solder pins

电缆出线范围 (仅限于插头)
Wire diameter (not only for plug)

- A = 5-10mm
 - B = 7-12mm
 - C = 9-14mm
 - D = 13-18mm
 - E = 17-24mm
 - F = 21-28mm
- } 仅限于
Not only for M23

排列顺序 (仅限于信号连接器)
Contact layout (not only for
singal connectors)

- CW = 顺时针 clockwise
- CCW= 逆时针 counterclockwise

M23 连接器 CONNECTOR

M23 信号直型接插件安装方式 Installation Mode of Signal Direct Connector

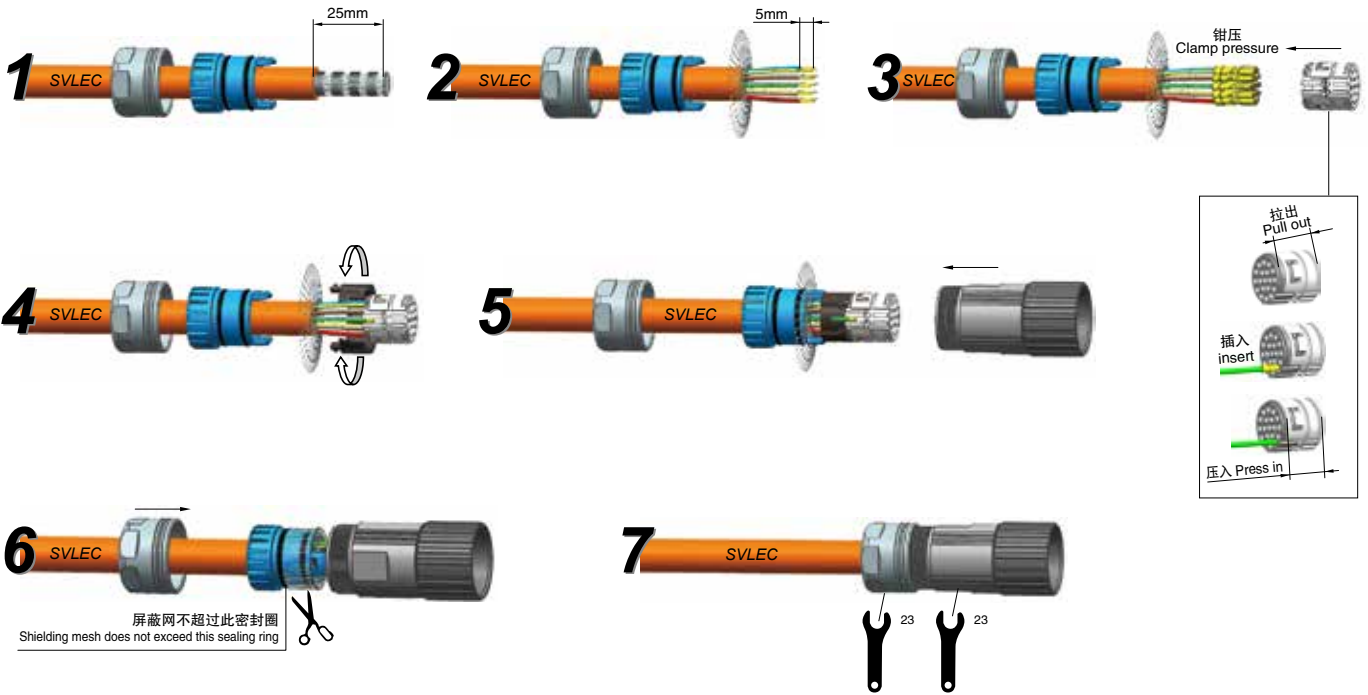

M23 信号板面弯角接插件安装方式 Installation Method of Signal Plate Bend Corner Connector

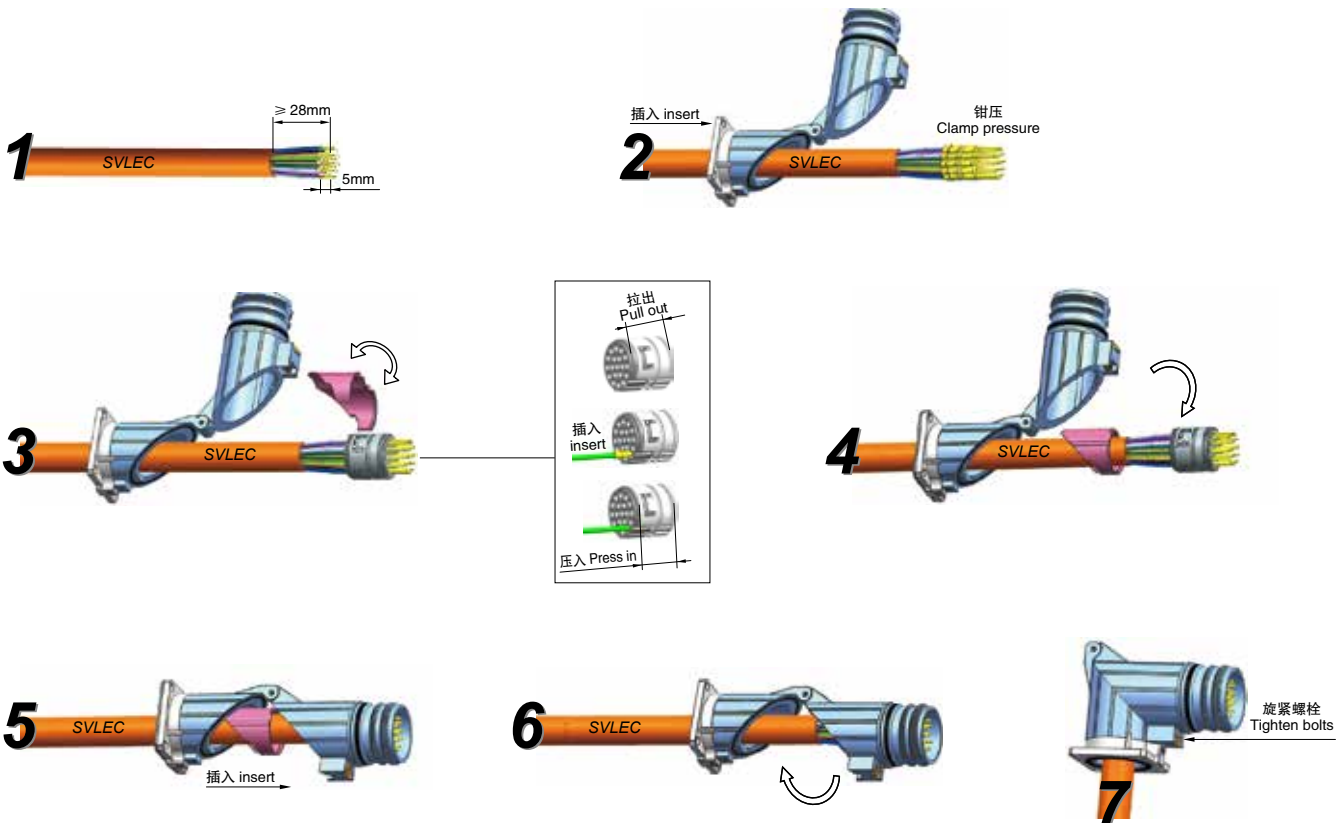

M23 连接器 CONNECTOR

M23 信号板面接插件安装方式 Installation Method of Signal Board Surface Connector

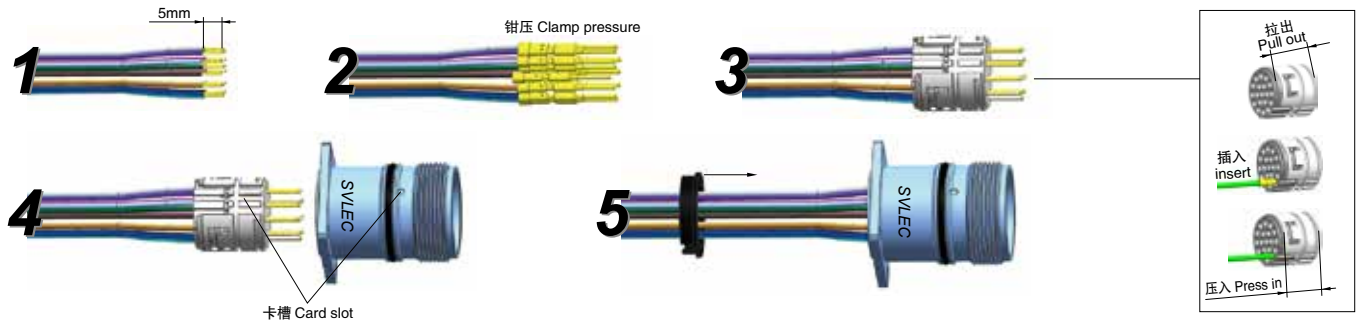

M23 动力直型接插件安装方式 Installation Mode of Power Direct Connector

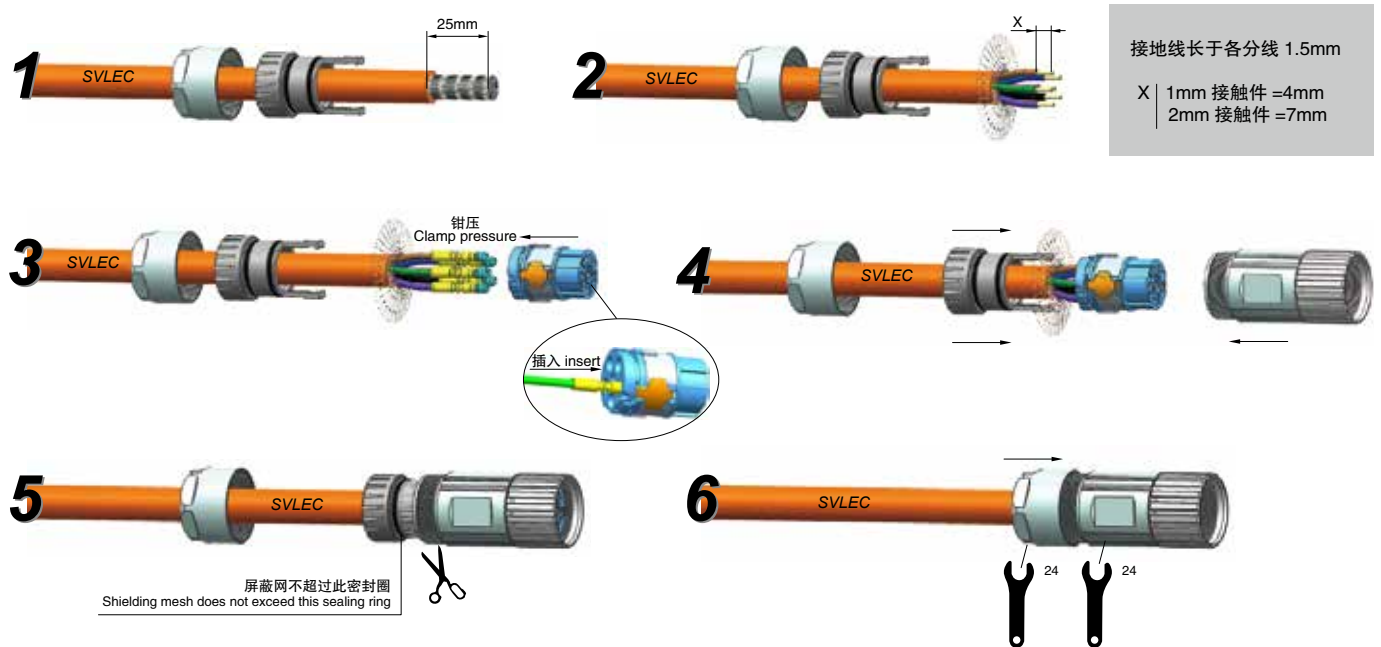

M23 动力板面弯角接插件安装方式 Installation Method of Power Plate Bend Corner Connector

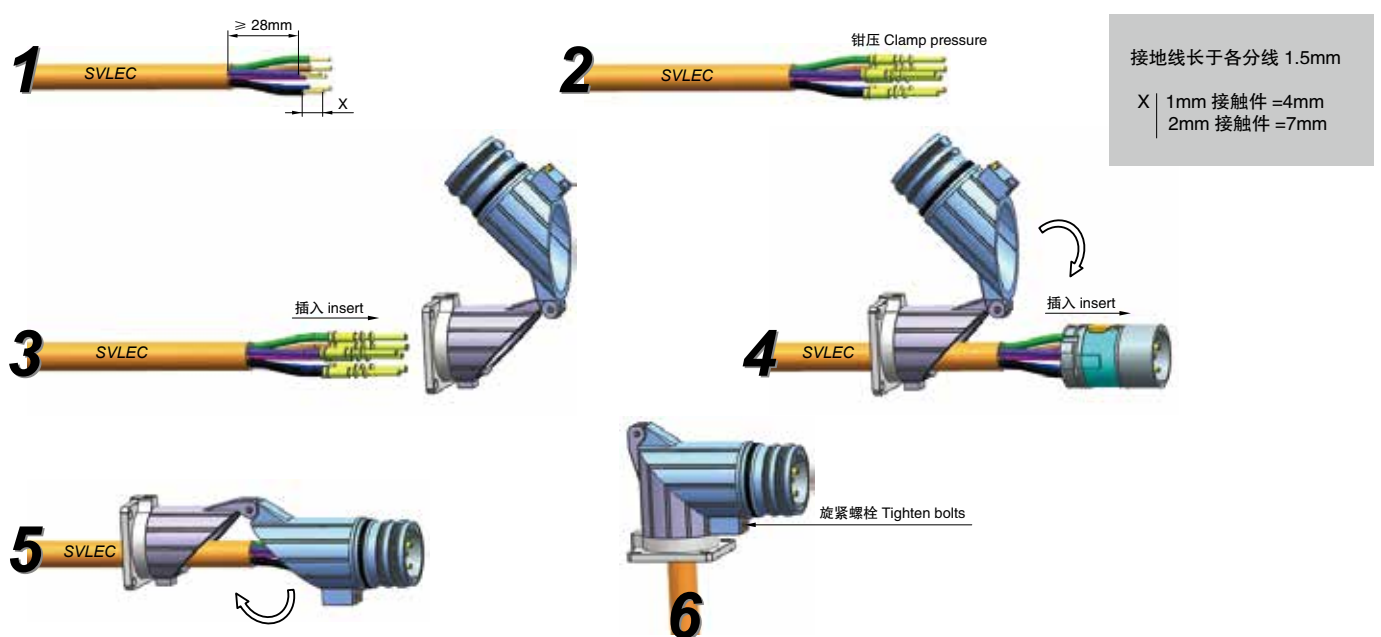

M23 连接器 CONNECTOR

现场接线
Field-wireable

M23 圆形连接器 Round plug connector (9,12)-pole
插孔 直出线 Female straight



M23 信号连接器

1	No.	923091	923092	923093	923094	923121	923122
	型号 Form	RC-M23-SPS-9F-CCW	RC-M23-SPS-9F-CW	RC-M23-SPS-(8+1)F-CCW	RC-M23-SPS-(8+1)F-CW	RC-M23-SPS-12F-CCW	RC-M23-SPS-12F-CW
	极数	9xØ1mm	9xØ1mm	8x1mm+1x2mm	8x1mm+1x2mm	12xØ1mm	12xØ1mm
	Suppression	9-pole	9-pole	9-pole	9-pole	12-pole	12-pole

尺寸图 Description

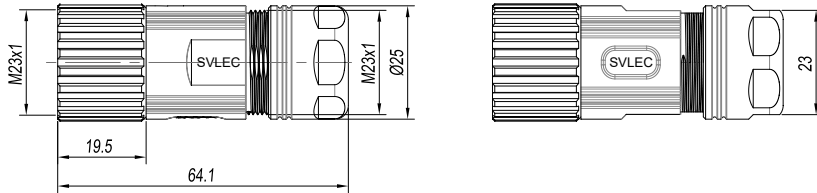

压线范围 Wire diameter

7-14mm

针脚排序
Contact layout

插孔 Female	插孔 Female	插孔 Female	插孔 Female	插孔 Female	插孔 Female	插孔 Female
逆时针 counterclockwise	顺时针 clockwise	逆时针 counterclockwise	顺时针 clockwise	逆时针 counterclockwise	逆时针 counterclockwise	顺时针 clockwise

2 技术参数 Technical data

额定电压 Supply voltage	160 V AC/DC
额定电流 Current per contact	10A
防护等级 Protection	IP67- 插孔插针配合拧紧 When plugged and screw down
温度范围 Temperature range	-20...+130°C
测试电压 (两插针之间) Test voltage	2500V
外壳材料 Housing material	锌合金压铸件 黄铜, 镀镍 Zinc alloy die casting Brass, nickel plating
绝缘内嵌体材料 Insulation embedded body material	PA66/PBT, UL 94/V0

接触件 (插孔)
Contact element (female)

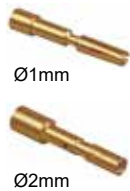

类型 Type	压线范围 Wire diameter	订货号 Part No.
插孔 Female Ø1mm	0.03-0.34mm ²	916201
	0.14-1.00mm ²	916221
插孔 Female Ø2mm	0.50-1.50mm ²	916231
	0.50-1.50mm ²	956221

订货号 Part No.

1 型号 Form

备注 Notes



M23 连接器 CONNECTOR

现场接线
Field-wireable

M23 圆形连接器 Round plug connector (17,16+3)-pole
插孔 直出线 Female straight



M23 信号连接器

1	No.	923171	923172	923191	923192															
型号 Form		RC-M23-SPS-17F-CCW	RC-M23-SPS-17F-CW	RC-M23-SPS-19F-CCW	RC-M23-SPS-19F-CW															
极数 Suppression		17xØ1mm 17-pole	17xØ1mm 17-pole	16xØ1mm+3xØ1.5mm 19-pole	16xØ1mm+3xØ1.5mm 19-pole															
尺寸图 Description																				
压线范围 Wire diameter		7-14mm																		
针脚排序 Contact layout		<p>插孔 Female 逆时针 counterclockwise</p>	<p>插孔 Female 顺时针 clockwise</p>	<p>插孔 Female 逆时针 counterclockwise</p>	<p>插孔 Female 顺时针 clockwise</p>															
2	技术参数 Technical data																			
额定电压 Supply voltage	160 V AC/DC			125 V AC/DC																
额定电流 Current per contact	8A																			
防护等级 Protection	IP67- 插孔插针配合拧紧 When plugged and screw down																			
温度范围 Temperature range	-20...+130°C																			
测试电压 (两插针之间) Test voltage	2500V																			
外壳材料 Housing material	锌合金压铸件 黄铜, 镀镍 Zinc alloy die casting Brass, nickel plating																			
绝缘内嵌体材料 Insulation embedded body material	PA66/PBT, UL 94/V0																			
接触件 (插孔) Contact element (female)	 Ø1mm  Ø1.5mm	<table border="1"> <thead> <tr> <th>类型 Type</th> <th>压线范围 Wire diameter</th> <th>订货号 Part No.</th> </tr> </thead> <tbody> <tr> <td rowspan="3">插孔 Female Ø1mm</td> <td>0.03-0.34mm²</td> <td>916201</td> </tr> <tr> <td>0.14-1.00mm²</td> <td>916221</td> </tr> <tr> <td>0.50-1.50mm²</td> <td>916231</td> </tr> <tr> <td rowspan="2">插孔 Female Ø1.5mm</td> <td>0.24-1.00mm²</td> <td>936201</td> </tr> <tr> <td>0.50-1.50mm²</td> <td>936221</td> </tr> </tbody> </table>	类型 Type	压线范围 Wire diameter	订货号 Part No.	插孔 Female Ø1mm	0.03-0.34mm ²	916201	0.14-1.00mm ²	916221	0.50-1.50mm ²	916231	插孔 Female Ø1.5mm	0.24-1.00mm ²	936201	0.50-1.50mm ²	936221			
类型 Type	压线范围 Wire diameter	订货号 Part No.																		
插孔 Female Ø1mm	0.03-0.34mm ²	916201																		
	0.14-1.00mm ²	916221																		
	0.50-1.50mm ²	916231																		
插孔 Female Ø1.5mm	0.24-1.00mm ²	936201																		
	0.50-1.50mm ²	936221																		
订货号 Part No.		_____ - _____ - _____																		
		1 型号 Form																		
备注 Notes																				

M23 连接器 CONNECTOR

现场接线
Field-wireable

M23 圆形连接器 Round plug connector (9,12)-pole
插针 Male 0° 法兰安装 Flange installation



M23 信号连接器

1	No.	923393	923395	923394	923397	923321	923322
型号 Form		RC-M23-SBS-9M-CCW-F	RC-M23-SBS-(8+1)M-CCW-F	RC-M23-SBS-9M-CW-F	RC-M23-SBS-(8+1)M-CW-F	RC-M23-SBS-12M-CCW-F	RC-M23-SBS-12M-CW-F
极数 Suppression		9xØ1mm 9-pole	8x1mm+1x2mm 9-pole	9xØ1mm 9-pole	8x1mm+1x2mm 9-pole	12xØ1mm 12-pole	12xØ1mm 12-pole

尺寸图 Description

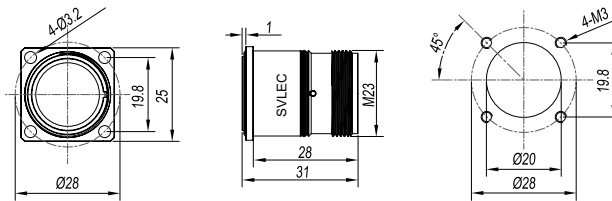

针脚排序
Contact layout

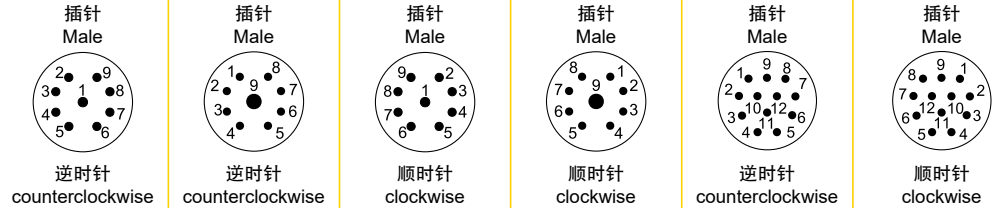

2 技术参数 Technical data

额定电压 Supply voltage	160 V AC/DC
额定电流 Current per contact	10A
防护等级 Protection	IP67- 插孔插针配合拧紧 When plugged and screwed down
温度范围 Temperature range	-20...+130°C
测试电压 (两插针之间) Test voltage	2500V
外壳材料 Housing material	锌合金压铸件 黄铜, 镀镍 Zinc alloy die casting Brass, nickel plating
绝缘内嵌体材料 Insulation embedded body material	PA66/PBT, UL 94/V0

接触件 (插针)
Contact element (male)



类型 Type	压线范围 Wire diameter	订货号 Part No.
插针 Male Ø1mm	0.03-0.34mm ²	916101
	0.14-1.00mm ²	916121
	0.50-1.50mm ²	916131
插针 Male Ø2mm	0.50-1.50mm ²	956121

订货号 Part No.

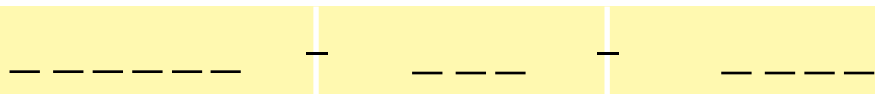

1 型号 Form

备注 Notes

M23 连接器 CONNECTOR

现场接线
Field-wireable

M23 圆形连接器 Round plug connector (17,16+3)-pole
插针 Male 0° 法兰安装 Flange installation

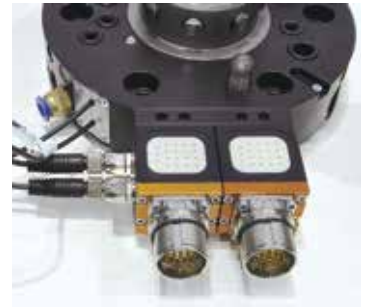

M23 信号连接器

1	No.	923371	923372	923391	923392
型号 Form		RC-M23-SBS-17M-CCW-F	RC-M23-SBS-17M-CW-F	RC-M23-SBS-19M-CCW-F	RC-M23-SBS-19M-CW-F
极数 Suppression		17xØ1mm 17-pole	17xØ1mm 17-pole	16xØ1mm+3xØ1.5mm 19-pole	16xØ1mm+3xØ1.5mm 19-pole

尺寸图 Description

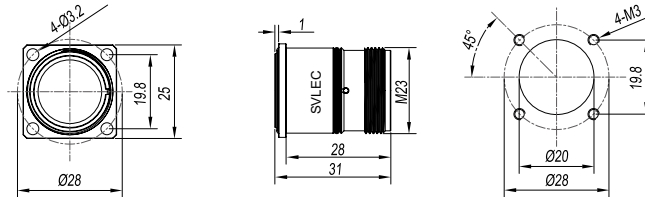

针脚排序
Contact layout

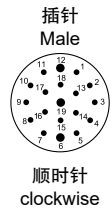
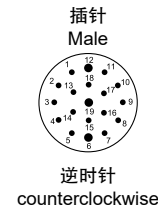
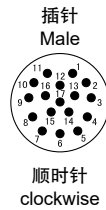
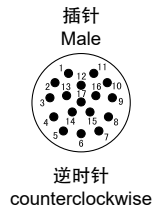

2	技术参数 Technical data				
额定电压 Supply voltage	160 V AC/DC			125 V AC/DC	
额定电流 Current per contact	8A				
防护等级 Protection	IP67- 插孔插针配合拧紧 When plugged and screwed down				
温度范围 Temperature range	-20...+130°C				
测试电压 (两插针之间) Test voltage	2500V				
外壳材料 Housing material	锌合金压铸件 黄铜, 镀镍 Zinc alloy die casting Brass, nickel plating				
绝缘内嵌体材料 Insulation embedded body material	PA66/PBT, UL 94/V0				

接触件 (插针)
Contact element (male)



类型 Type	压线范围 Wire diameter	订货号 Part No.
插针 Male Ø1mm	0.03-0.34mm ²	916101
	0.14-1.00mm ²	916121
	0.50-1.50mm ²	916131
插针 Male Ø1.5mm	0.24-1.00mm ²	936101
	0.50-1.50mm ²	936121

订货号 Part No.

1 型号 Form

备注 Notes

M23 连接器 CONNECTOR

现场接线
Field-wireable

M23 圆形连接器 Round plug connector (9,12)-pole
插针 Male 90° 法兰安装 Flange installation



M23 信号连接器

1	No.	923491	923495	923492	923497	923421	923422
	型号 Form	RC-M23-SBR-9M-CCW-F	RC-M23-SBR-(8+1)M-CCW-F	RC-M23-SBR-9M-CW-F	RC-M23-SBR-(8+1)M-CW-F	RC-M23-SBR-12M-CCW-F	RC-M23-SBR-12M-CW-F
	极数	9xØ1mm	8x1mm+1x2mm	9xØ1mm	8x1mm+1x2mm	12xØ1mm	12xØ1mm
	Suppression	9-pole	9-pole	9-pole	9-pole	12-pole	12-pole

尺寸图 Description

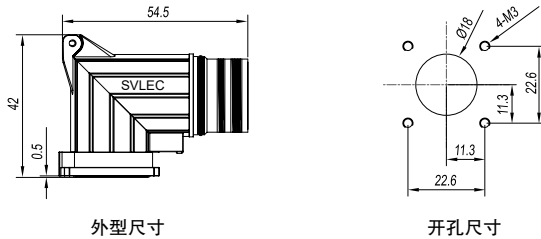

针脚排序 Contact layout

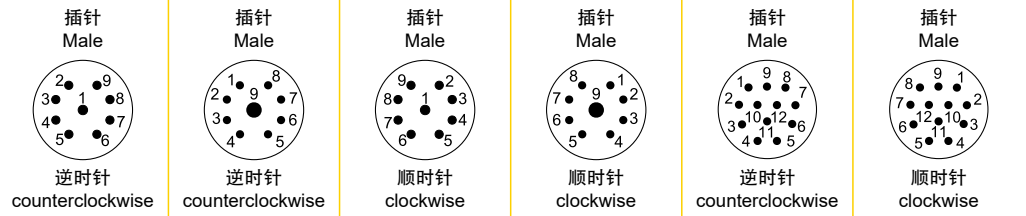

2 技术参数 Technical data

额定电压 Supply voltage	160 V AC/DC
额定电流 Current per contact	10A
防护等级 Protection	IP67- 插孔插针配合拧紧 When plugged and screwed down
温度范围 Temperature range	-20...+130°C
测试电压 (两插针之间) Test voltage	2500V
外壳材料 Housing material	锌合金压铸件 黄铜, 镀镍 Zinc alloy die casting Brass, nickel plating
绝缘内嵌体材料 Insulation embedded body material	PA66/PBT, UL 94/V0

接触件 (插针) Contact element (male)

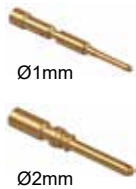

类型 Type	压线范围 Wire diameter	订货号 Part No.
插针 Male Ø1mm	0.03-0.34mm ²	916101
	0.14-1.00mm ²	916121
插针 Male Ø2mm	0.50-1.50mm ²	916131
	0.50-1.50mm ²	956121

订货号 Part No.

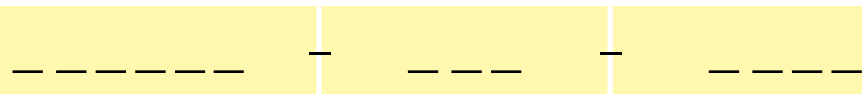

1 型号 Form

备注 Notes

M23 连接器 CONNECTOR

现场接线
Field-wireable

M23 圆形连接器 Round plug connector (17,16+3)-pole
插针 Male 90° 法兰安装 Flange installation



M23 信号连接器

1	No.	923471	923472	923493	923494
型号 Form		RC-M23-SBR-17M-CCW-F	RC-M23-SBR-17M-CW-F	RC-M23-SBR-19M-CCW-F	RC-M23-SBR-19M-CW-F
极数 Suppression		17xØ1mm 17-pole	17xØ1mm 17-pole	16xØ1mm+3xØ1.5mm 19-pole	16xØ1mm+3xØ1.5mm 19-pole

尺寸图 Description

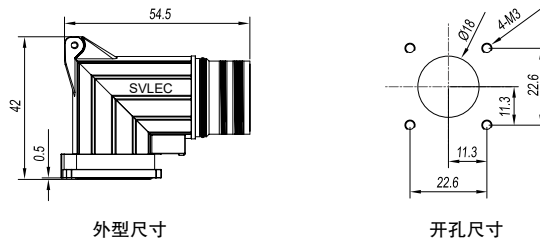

针脚排序
Contact layout

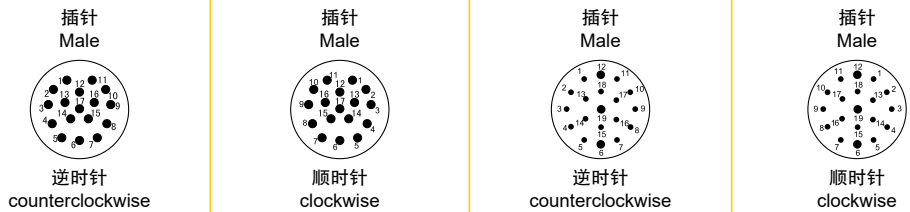

2	技术参数 Technical data				
额定电压 Supply voltage	160 V AC/DC			125 V AC/DC	
额定电流 Current per contact	8A				
防护等级 Protection	IP67- 插孔插针配合拧紧 When plugged and screwed down				
温度范围 Temperature range	-20...+130°C				
测试电压 (两插针之间) Test voltage	2500V				
外壳材料 Housing material	锌合金压铸件 黄铜, 镀镍 Zinc alloy die casting Brass, nickel plating				
绝缘内嵌体材料 Insulation embedded body material	PA66/PBT, UL 94/V0				

接触件 (插针)
Contact element (male)



类型 Type	压线范围 Wire diameter	订货号 Part No.
插针 Male Ø1mm	0.03~0.34mm ²	916101
	0.14~1.00mm ²	916121
	0.50~1.50mm ²	916131
插针 Male Ø1.5mm	0.24~1.00mm ²	936101
	0.50~1.50mm ²	936121

订货号 Part No.

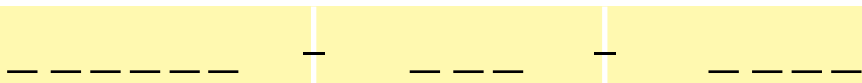

1 型号 Form

备注 Notes

M23 连接器 CONNECTOR

现场接线
Field-wireable

M23 圆形连接器 Round plug connector (9,12)-pole
插针 延长式连接器 Male Extended type connector



M23 信号连接器

1	No.	923591	923595	923592	923597	923521	923522														
型号 Form		RC-M23-SCC-9M-CCW	RC-M23-SCC-(8+1)M-CCW	RC-M23-SCC-9M-CW	RC-M23-SCC-(8+1)M-CW	RC-M23-SCC-12M-CCW	RC-M23-SCC-12M-CW														
极数 Suppression		9xØ1mm	8x1mm+1x2mm	9xØ1mm	8x1mm+1x2mm	12xØ1mm	12xØ1mm														
尺寸图 Description																					
压线范围 Wire diameter		7-14mm																			
针脚排序 Contact layout		<p>插针 Male 逆时针 counterclockwise</p>	<p>插针 Male 逆时针 counterclockwise</p>	<p>插针 Male 顺时针 clockwise</p>	<p>插针 Male 顺时针 clockwise</p>	<p>插针 Male 逆时针 counterclockwise</p>	<p>插针 Male 顺时针 clockwise</p>														
2 技术参数 Technical data																					
额定电压 Supply voltage		160 V AC/DC																			
额定电流 Current per contact		10A					8A														
防护等级 Protection		IP67- 插孔插针配合拧紧 When plugged and screwed down																			
温度范围 Temperature range		-20...+130°C																			
测试电压 (两插针之间) Test voltage		2500V																			
外壳材料 Housing material		锌合金压铸件 黄铜, 镀镍 Zinc alloy die casting Brass, nickel plating																			
绝缘内嵌体材料 Insulation embedded body material		PA66/PBT, UL 94/V0																			
接触件 (插针) Contact element (male)		<p>Ø1mm</p> <p>Ø2mm</p>	<table border="1"> <thead> <tr> <th>类型 Type</th> <th>压线范围 Wire diameter</th> <th>订货号 Part No.</th> </tr> </thead> <tbody> <tr> <td rowspan="3">插针 Male Ø1mm</td> <td>0.03-0.34mm²</td> <td>916101</td> </tr> <tr> <td>0.14-1.00mm²</td> <td>916121</td> </tr> <tr> <td>0.50-1.50mm²</td> <td>916131</td> </tr> <tr> <td>插针 Male Ø2mm</td> <td>0.50-1.50mm²</td> <td>956121</td> </tr> </tbody> </table>	类型 Type	压线范围 Wire diameter	订货号 Part No.	插针 Male Ø1mm	0.03-0.34mm ²	916101	0.14-1.00mm ²	916121	0.50-1.50mm ²	916131	插针 Male Ø2mm	0.50-1.50mm ²	956121					
类型 Type	压线范围 Wire diameter	订货号 Part No.																			
插针 Male Ø1mm	0.03-0.34mm ²	916101																			
	0.14-1.00mm ²	916121																			
	0.50-1.50mm ²	916131																			
插针 Male Ø2mm	0.50-1.50mm ²	956121																			
订货号 Part No.																					
<div style="text-align: center;"> - </div>																					
1 型号 Form																					
备注 Notes																					



M23 连接器 CONNECTOR

现场接线
Field-wireable

M23 圆形连接器 Round plug connector (17,19)-pole
插针 延长式连接器 Male Extended type connector

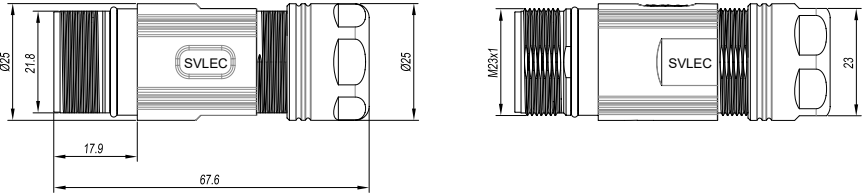
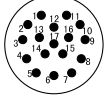
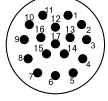
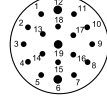
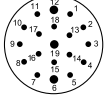

M23 信号连接器

1	No.	923571	923572	923593	923594															
型号 Form		RC-M23-SCC-17M-CCW	RC-M23-SCC-17M-CW	RC-M23-SCC-19M-CCW	RC-M23-SCC-19M-CW															
极数 Suppression		17xØ1mm 17-pole	17xØ1mm 17-pole	16xØ1mm+3xØ1.5mm 19-pole	16xØ1mm+3xØ1.5mm 19-pole															
尺寸图 Description																				
压线范围 Wire diameter		7-14mm																		
针脚排序 Contact layout		 插针 Male 逆时针 counterclockwise	 插针 Male 顺时针 clockwise	 插针 Male 逆时针 counterclockwise	 插针 Male 顺时针 clockwise															
2	技术参数 Technical data																			
额定电压 Supply voltage	160 V AC/DC			125 V AC/DC																
额定电流 Current per contact	8A																			
防护等级 Protection	IP67- 插孔插针配合拧紧 When plugged and screw down																			
温度范围 Temperature range	-20...+130°C																			
测试电压 (两插针之间) Test voltage	2500V																			
外壳材料 Housing material	锌合金压铸件 黄铜, 镀镍 Zinc alloy die casting Brass, nickel plating																			
绝缘内嵌体材料 Insulation embedded body material	PA66/PBT, UL 94/V0																			
接触件 (插针) Contact element (male)	 Ø1mm  Ø1.5mm	<table border="1"> <thead> <tr> <th>类型 Type</th> <th>压线范围 Wire diameter</th> <th>订货号 Part No.</th> </tr> </thead> <tbody> <tr> <td rowspan="3">插针 Male Ø1mm</td> <td>0.03-0.34mm²</td> <td>916101</td> </tr> <tr> <td>0.14-1.00mm²</td> <td>916121</td> </tr> <tr> <td>0.50-1.50mm²</td> <td>916131</td> </tr> <tr> <td rowspan="2">插针 Male Ø1.5mm</td> <td>0.24-1.00mm²</td> <td>936101</td> </tr> <tr> <td>0.50-1.50mm²</td> <td>936121</td> </tr> </tbody> </table>	类型 Type	压线范围 Wire diameter	订货号 Part No.	插针 Male Ø1mm	0.03-0.34mm ²	916101	0.14-1.00mm ²	916121	0.50-1.50mm ²	916131	插针 Male Ø1.5mm	0.24-1.00mm ²	936101	0.50-1.50mm ²	936121			
类型 Type	压线范围 Wire diameter	订货号 Part No.																		
插针 Male Ø1mm	0.03-0.34mm ²	916101																		
	0.14-1.00mm ²	916121																		
	0.50-1.50mm ²	916131																		
插针 Male Ø1.5mm	0.24-1.00mm ²	936101																		
	0.50-1.50mm ²	936121																		
订货号 Part No.	_____ - _____ - _____																			
	1	型号 Form																		
备注 Notes																				

M23 连接器 CONNECTOR

现场接线
Field-wireable

M23 圆形连接器 Round plug connector (9,12)-pole
插针 中间固定式连接器 Male Fixed connector



M23 信号连接器

1	No.	923981	923983	923985	923987	923281	923283
型号 Form		RC-M23-SPF-9M-CCW	RC-M23-SPF-(8+1)M-CCW	RC-M23-SPF-9M-CW	RC-M23-SPF-(8+1)M-CW	RC-M23-SPF-12M-CCW	RC-M23-SPF-12M-CW
极数 Suppression		9xØ1mm	8x1mm+1x2mm	9xØ1mm	8x1mm+1x2mm	12xØ1mm	12xØ1mm
尺寸图 Description							
外型尺寸							

压线范围 Wire diameter 7-14mm

针脚排序
Contact layout

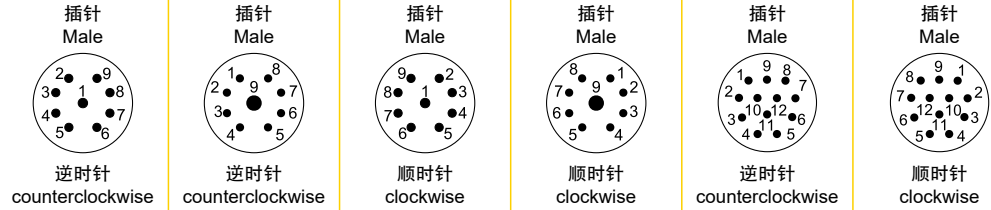

2 技术参数 Technical data

额定电压 Supply voltage	160 V AC/DC	
额定电流 Current per contact	10A	8A
防护等级 Protection	IP67- 插孔插针配合拧紧 When plugged and screwed down	
温度范围 Temperature range	-20...+130°C	
测试电压 (两插针之间) Test voltage	2500V	
外壳材料 Housing material	锌合金压铸件 黄铜, 镀镍 Zinc alloy die casting Brass, nickel plating	
绝缘内嵌体材料 Insulation embedded body material	PA66/PBT, UL 94/V0	

接触件 (插针)
Contact element (male)



类型 Type	压线范围 Wire diameter	订货号 Part No.
插针 Male Ø1mm	0.03-0.34mm ²	916101
	0.14-1.00mm ²	916121
	0.50-1.50mm ²	916131
插针 Male Ø2mm	0.50-1.50mm ²	956121

订货号 Part No.

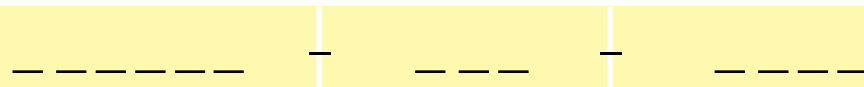

1 型号 Form

备注 Notes

M23 连接器 CONNECTOR



现场接线
Field-wireable

M23 圆形连接器 Round plug connector (17,19)-pole
插针 中间固定式连接器 Male Fixed connector



M23 信号连接器

1	No.	923781	923783	923923	923925
型号 Form		RC-M23-SPF-17M-CCW	RC-M23-SPF-17M-CW	RC-M23-SPF-19M-CCW	RC-M23-SPF-19M-CW
极数 Suppression		17xØ1mm 17-pole	17xØ1mm 17-pole	16xØ1mm+3xØ1.5mm 19-pole	16xØ1mm+3xØ1.5mm 19-pole

尺寸图 Description

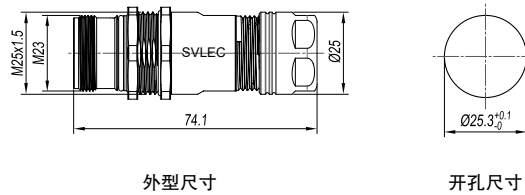

压线范围 Wire diameter 7-14mm

针脚排序
Contact layout

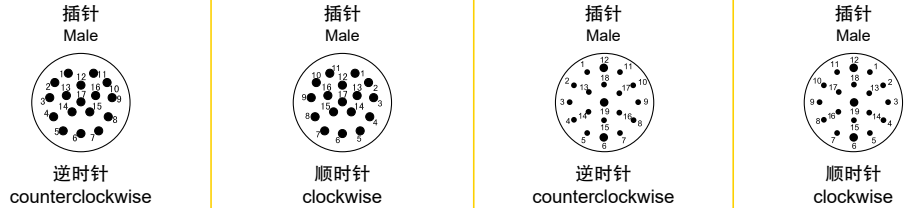

2 技术参数 Technical data

额定电压 Supply voltage	160 V AC/DC	125 V AC/DC
额定电流 Current per contact	8A	
防护等级 Protection	IP67- 插孔插针配合拧紧 When plugged and screwed down	
温度范围 Temperature range	-20...+130°C	
测试电压(两插针之间) Test voltage	2500V	
外壳材料 Housing material	锌合金压铸件 黄铜, 镀镍 Zinc alloy die casting Brass, nickel plating	
绝缘内嵌体材料 Insulation embedded body material	PA66/PBT, UL 94/V0	

接触件 (插针)
Contact element (male)



类型 Type	压线范围 Wire diameter	订货号 Part No.
插针 Male Ø1mm	0.03-0.34mm ²	916101
	0.14-1.00mm ²	916121
	0.50-1.50mm ²	916131
插针 Male Ø1.5mm	0.24-1.00mm ²	936101
	0.50-1.50mm ²	936121

订货号 Part No.

_____ - _____ - _____

1 型号 Form

备注 Notes

M23 连接器 CONNECTOR

现场接线
Field-wireable

插针 Male
直出线 straight

M23 信号连接器

1	No.	923688	923888													
型号 Form	RC-M23-PPT-6M	RC-M23-PPT-8M														
极数 Suppression	6-pole	8-pole														
尺寸图 Description	<p>外型尺寸</p>															
针脚排序 Contact layout																
2	技术参数 Technical data															
额定电压 Supply voltage	630 V AC/DC															
额定电流 Current per contact	30A															
防护等级 Protection	IP67- 插孔插针配合拧紧 When plugged and screwed down															
温度范围 Temperature range	-20...+130°C															
测试电压 (两插针之间) Test voltage	2500V															
外壳材料 Housing material	铜镀镍															
绝缘内嵌体材料 Insulation embedded body material	PA66/PBT, UL 94/V0															
接触件 (插针) Contact element (male)	<p>Ø1mm</p> <p>Ø2mm</p>	<table border="1"> <thead> <tr> <th>类型 Type</th> <th>压线范围 Wire diameter</th> <th>订货号 Part No.</th> </tr> </thead> <tbody> <tr> <td rowspan="3">插针 Male Ø1mm</td> <td>0.03-0.34mm²</td> <td>916101</td> </tr> <tr> <td>0.14-1.00mm²</td> <td>916121</td> </tr> <tr> <td>0.50-1.50mm²</td> <td>916131</td> </tr> <tr> <td>插针 Male Ø2mm</td> <td>0.50-1.50mm²</td> <td>956121</td> </tr> </tbody> </table>	类型 Type	压线范围 Wire diameter	订货号 Part No.	插针 Male Ø1mm	0.03-0.34mm ²	916101	0.14-1.00mm ²	916121	0.50-1.50mm ²	916131	插针 Male Ø2mm	0.50-1.50mm ²	956121	
类型 Type	压线范围 Wire diameter	订货号 Part No.														
插针 Male Ø1mm	0.03-0.34mm ²	916101														
	0.14-1.00mm ²	916121														
	0.50-1.50mm ²	916131														
插针 Male Ø2mm	0.50-1.50mm ²	956121														
订货号 Part No.	<p>----- ----- ----- -----</p> <p>1 型号 Form</p>															
备注 Notes																

M23 连接器 CONNECTOR

现场接线
Field-wireable
6-pole
3+PE+4-pole
3+PE+5-pole

插孔 Female
直出线 straight



M23 动力连接器

1	No.	923401	923601	923801	923901											
	型号 Form	RC-M23-PPS-4F	RC-M23-PPS-6F	RC-M23-PPS-8F	RC-M23-PPS-9F											
	极数 Suppression	4p(4xØ2)	6p(6xØ2)	8p(4xØ2+4xØ1)	9p(4xØ2+5xØ1)											
	尺寸图 Description															
压线范围 Wire diameter	7-17mm															
针脚排序 Contact layout																
2	技术参数 Technical data															
额定电压 Supply voltage	630 V AC/DC		630 V (AC/DC) / 250 V (AC/DC)													
额定电流 Current per contact	28A		28A / 10A													
防护等级 Protection	IP67- 插孔插针配合拧紧 When plugged and screwed down															
温度范围 Temperature range	-20...+130°C															
测试电压 (两插针之间) Test voltage	4000V		4000V / 2500V													
外壳材料 Housing material	锌合金压铸件 黄铜, 镀镍 Zinc alloy die casting Brass, nickel plating															
绝缘内嵌体材料 Insulation embedded body material	PA66/PBT, UL 94/V0															
接触件 (插孔) Contact element (female)		<table border="1"> <thead> <tr> <th>类型 Type</th> <th>压线范围 Wire diameter</th> <th>订货号 Part No.</th> </tr> </thead> <tbody> <tr> <td>插孔 Female Ø1mm</td> <td>0.25~1.00mm²</td> <td>916431</td> </tr> <tr> <td rowspan="2">插孔 Female Ø2mm</td> <td>1.00~2.50mm²</td> <td>926201</td> </tr> <tr> <td>2.50~4.00mm²</td> <td>926221</td> </tr> </tbody> </table>	类型 Type	压线范围 Wire diameter	订货号 Part No.	插孔 Female Ø1mm	0.25~1.00mm ²	916431	插孔 Female Ø2mm	1.00~2.50mm ²	926201	2.50~4.00mm ²	926221			
类型 Type	压线范围 Wire diameter	订货号 Part No.														
插孔 Female Ø1mm	0.25~1.00mm ²	916431														
插孔 Female Ø2mm	1.00~2.50mm ²	926201														
	2.50~4.00mm ²	926221														
订货号 Part No.	<div style="display: flex; justify-content: space-around; align-items: center;"> — — — — — — — — — — — — — — — — — </div>															
	1 型号 Form															
备注 Notes																

M23 连接器 CONNECTOR

M23 圆形连接器
 Round plug connector

现场接线
 Field-wireable

6-pole

3+PE+4-pole



3+PE+5-pole

插针 Male 0°
 法兰安装 Flange installation



插针 Male 90°
 法兰安装 Flange installation

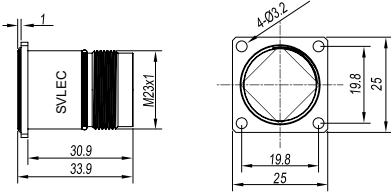
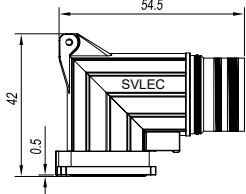
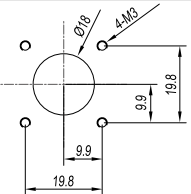
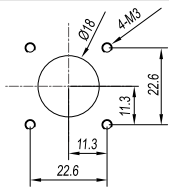
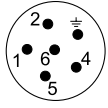
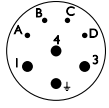
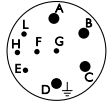
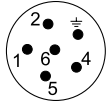
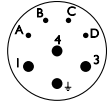
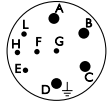

1	No.	923621	923821	923921	923641	923841	923941											
型号 Form		RC-M23-PBS-6M-F	RC-M23-PBS-8M-F	RC-M23-PBS-9M-F	RC-M23-PBR-6M-F	RC-M23-PBR-8M-F	RC-M23-PBR-9M-F											
极数 Suppression		6p(6xØ2)	8p(4xØ2+4xØ1)	9p(4xØ2+5xØ1)	6p(6xØ2)	8p(4xØ2+4xØ1)	9p(4xØ2+5xØ1)											
尺寸图 Description																		
开孔尺寸																		
针脚排序 Contact layout																		
2 技术参数 Technical data																		
额定电压 Supply voltage		630 V AC/DC	630 V (AC/DC) / 250 V (AC/DC)		630 V AC/DC	630 V (AC/DC) / 250 V (AC/DC)												
额定电流 Current per contact		28A	28A / 10A		28A	28A / 10A												
防护等级 Protection		IP67- 插孔插针配合拧紧 When plugged and screw down																
温度范围 Temperature range		-20...+130°C																
测试电压 (两插针之间) Test voltage		4000V	4000V / 2500V		4000V	4000V / 2500V												
外壳材料 Housing material		锌合金压铸件 黄铜, 镀镍 Zinc alloy die casting Brass, nickel plating																
绝缘内嵌体材料 Insulation embedded body material		PA66/PBT, UL 94/V0																
接触件 (插针) Contact element (male)		 Ø1mm	<table border="1"> <thead> <tr> <th>类型 Type</th> <th>压线范围 Wire diameter</th> <th>订货号 Part No.</th> </tr> </thead> <tbody> <tr> <td>插针 Male Ø1mm</td> <td>0.25~1.00mm²</td> <td>916331</td> </tr> <tr> <td rowspan="2">插针 Male Ø2mm</td> <td>1.00~2.50mm²</td> <td>926101</td> </tr> <tr> <td>2.50~4.00mm²</td> <td>926121</td> </tr> </tbody> </table>		类型 Type	压线范围 Wire diameter	订货号 Part No.	插针 Male Ø1mm	0.25~1.00mm ²	916331	插针 Male Ø2mm	1.00~2.50mm ²	926101	2.50~4.00mm ²	926121	 Ø2mm		
类型 Type	压线范围 Wire diameter	订货号 Part No.																
插针 Male Ø1mm	0.25~1.00mm ²	916331																
插针 Male Ø2mm	1.00~2.50mm ²	926101																
	2.50~4.00mm ²	926121																
订货号 Part No.		<div style="display: flex; justify-content: space-around; align-items: center;"> <div style="border-bottom: 1px dashed black; width: 20%;"></div> <div style="border-bottom: 1px dashed black; width: 20%;"></div> <div style="border-bottom: 1px dashed black; width: 20%;"></div> <div style="border-bottom: 1px dashed black; width: 20%;"></div> <div style="border-bottom: 1px dashed black; width: 20%;"></div> <div style="border-bottom: 1px dashed black; width: 20%;"></div> </div>																
		1 型号 Form																
备注 Notes																		



M23 连接器 CONNECTOR

现场接线
Field-wireable
6-pole
3+PE+4-pole
3+PE+5-pole

插针 延长式连接器 Male Extended type connector



M23 动力连接器

1	No.	923661	923881	923991											
	型号 Form	RC-M23-PCC-6M-B	RC-M23-PCC-8M-B	RC-M23-PCC-9M-B											
	极数 Suppression	6p(6xØ2)	8p(4xØ2+4xØ1)	9p(4xØ2+5xØ1)											
	尺寸图 Description														
压线范围 Wire diameter	7-17mm														
针脚排序 Contact layout															
2 技术参数 Technical data															
额定电压 Supply voltage	630 V AC/DC		630 V (AC/DC) / 250 V (AC/DC)												
额定电流 Current per contact	28A		28A / 10A												
防护等级 Protection	IP67- 插孔插针配合拧紧 When plugged and screwed down														
温度范围 Temperature range	-20...+130°C														
测试电压 (两插针之间) Test voltage	4000V		4000V / 2500V												
外壳材料 Housing material	锌合金压铸件 黄铜, 镀镍 Zinc alloy die casting Brass, nickel plating														
绝缘内嵌体材料 Insulation embedded body material	PA66/PBT, UL 94/V0														
接触件 (插针) Contact element (male)	 Ø1mm  Ø2mm	<table border="1"> <thead> <tr> <th>类型 Type</th> <th>压线范围 Wire diameter</th> <th>订货号 Part No.</th> </tr> </thead> <tbody> <tr> <td>插针 Male Ø1mm</td> <td>0.25~1.00mm²</td> <td>916331</td> </tr> <tr> <td rowspan="2">插针 Male Ø2mm</td> <td>1.00~2.50mm²</td> <td>926101</td> </tr> <tr> <td>2.50~4.00mm²</td> <td>926121</td> </tr> </tbody> </table>	类型 Type	压线范围 Wire diameter	订货号 Part No.	插针 Male Ø1mm	0.25~1.00mm ²	916331	插针 Male Ø2mm	1.00~2.50mm ²	926101	2.50~4.00mm ²	926121		
类型 Type	压线范围 Wire diameter	订货号 Part No.													
插针 Male Ø1mm	0.25~1.00mm ²	916331													
插针 Male Ø2mm	1.00~2.50mm ²	926101													
	2.50~4.00mm ²	926121													
订货号 Part No.	<div style="display: flex; justify-content: space-around; align-items: center;"> _____ _____ _____ </div>														
	1	型号 Form													
备注 Notes															

M40 连接器 CONNECTOR

M40 圆形连接器
Round plug connector

现场接线
Field-wireable

3+PE+2-pole







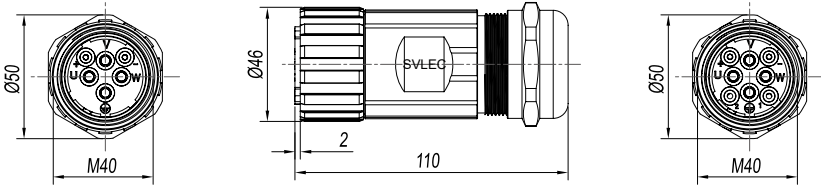
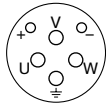
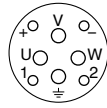

3+PE+4-pole

插孔 Female
直出线 Straight



插孔 Female
直出线 Straight



1	No.	940661	940681													
型号 Form		RC-M40-PPS-6F	RC-M40-PPS-8F													
极数 Suppression		6p(4 × Ø3.6+2 × Ø2)	8p(4 × Ø3.6+4 × Ø2)													
尺寸图 Description																
																
压线范围 Wire diameter		13-28mm														
针脚排序 Contact layout																
2 技术参数 Technical data																
额定电压 Supply voltage		630 V (AC/DC) / 250 V (AC/DC)														
额定电流 Current per contact		65A / 28A														
防护等级 Protection		IP67- 插孔插针配合拧紧 When plugged and screwed down														
温度范围 Temperature range		-20...+130°C														
测试电压 (两插针之间) Test voltage		4000V / 2500V														
外壳材料 Housing material		锌合金压铸件 黄铜, 镀镍 Zinc alloy die casting Brass, nickel plating														
绝缘内嵌体材料 Insulation embedded body material		PA66/PBT, UL 94/V0														
接触件 (插孔) Contact element (female)		<table border="1" style="width: 100%;"> <thead> <tr> <th style="width: 20%;">类型 Type</th> <th style="width: 30%;">压线范围 Wire diameter</th> <th style="width: 50%;">订货号 Part No.</th> </tr> </thead> <tbody> <tr> <td rowspan="2">  Ø2mm </td> <td>插孔 Female Ø2mm</td> <td>1.00-2.50mm² 926201</td> </tr> <tr> <td></td> <td>2.50-4.00mm² 926221</td> </tr> <tr> <td rowspan="3">  Ø3.6mm </td> <td rowspan="3">插孔 Female Ø3.6mm</td> <td>1.50-4.00mm² 936241</td> </tr> <tr> <td>6.00mm² 936261</td> </tr> <tr> <td>10.00mm² 936281</td> </tr> </tbody> </table>		类型 Type	压线范围 Wire diameter	订货号 Part No.	 Ø2mm	插孔 Female Ø2mm	1.00-2.50mm ² 926201		2.50-4.00mm ² 926221	 Ø3.6mm	插孔 Female Ø3.6mm	1.50-4.00mm ² 936241	6.00mm ² 936261	10.00mm ² 936281
类型 Type	压线范围 Wire diameter	订货号 Part No.														
 Ø2mm	插孔 Female Ø2mm	1.00-2.50mm ² 926201														
		2.50-4.00mm ² 926221														
 Ø3.6mm	插孔 Female Ø3.6mm	1.50-4.00mm ² 936241														
		6.00mm ² 936261														
		10.00mm ² 936281														
订货号 Part No.																
																
1 型号 Form																
备注 Notes																

M40 连接器 CONNECTOR

M40 圆形连接器
Round plug connector M40
现场接线
Field-wireable
3+PE+2-pole

插针 Male 0°
法兰安装 Flange installation



插针 Male 90°
法兰安装 Flange installation



1 No. **940631** **940651**

型号 Form	RC-M40-PBS-6M-F	RC-M40-PBR-6M-F
极数 Suppression	6p(4 × Ø3.6+2 × Ø2)	6p(4 × Ø3.6+2 × Ø2)

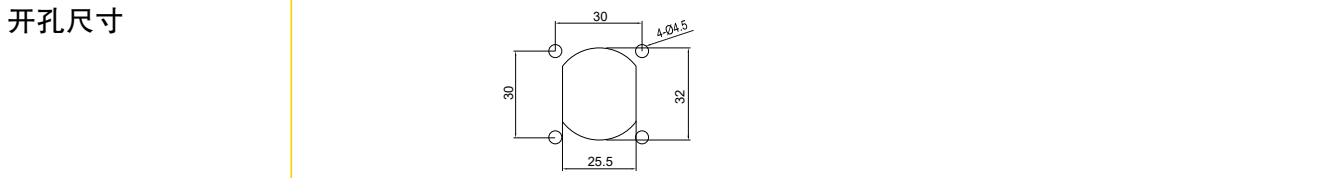
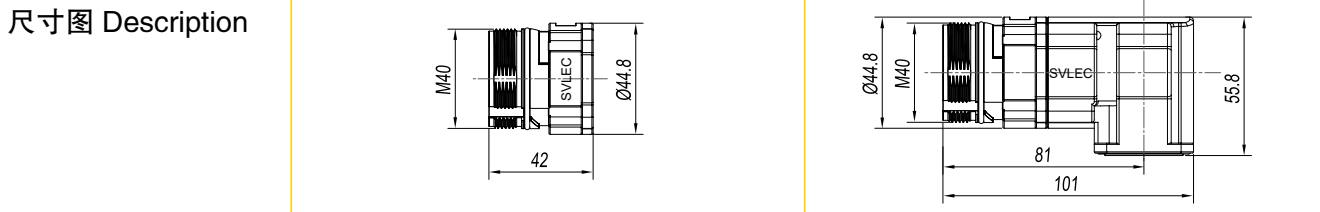

2 技术参数 Technical data

额定电压 Supply voltage	630 V (AC/DC) / 250 V (AC/DC)
额定电流 Current per contact	65A / 28A
防护等级 Protection	IP67- 插孔插针配合拧紧 When plugged and screwed down
温度范围 Temperature range	-20...+130°C
测试电压 (两插针之间) Test voltage	4000V / 2500V
外壳材料 Housing material	锌合金压铸件 黄铜, 镀镍 Zinc alloy die casting Brass, nickel plating
绝缘内嵌体材料 Insulation embedded body material	PA66/PBT, UL 94/V0

接触件 (插针) Contact element (male)	类型 Type	压线范围 Wire diameter	订货号 Part No.
 Ø2mm	插针 Male Ø2mm	1.00-2.50mm ²	926101
		2.50-4.00mm ²	926121
 Ø3.6mm	插针 Male Ø3.6mm	1.50-4.00mm ²	936141
		6.00mm ²	936161
		10.00mm ²	936181

订货号 Part No.



1 型号 Form

备注 Notes

M40 动力连接器

M40 连接器 CONNECTOR







M40 圆形连接器
 Round plug connector M40
 现场接线
 Field-wireable
 3+PE+4-pole

插针 Male 0°
 法兰安装 Flange installation

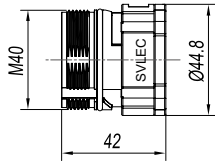
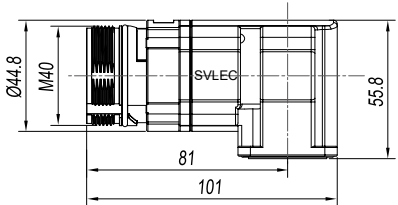
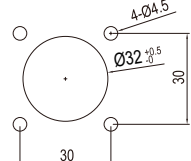
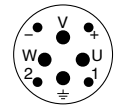

插针 Male 90°
 法兰安装 Flange installation

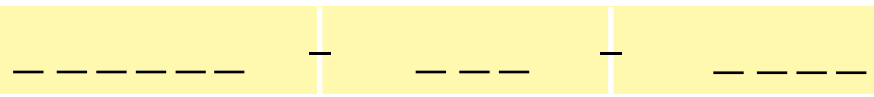

1	No.	940851	940871															
型号 Form		RC-M40-PBS-8M-F	RC-M40-PBR-8M-F															
极数 Suppression		8p(4 × Ø3.6+4 × Ø2)	8p(4 × Ø3.6+4 × Ø2)															
尺寸图 Description																		
开孔尺寸																		
针脚排序 Contact layout																		
2	技术参数 Technical data																	
额定电压 Supply voltage	630 V (AC/DC) / 250 V (AC/DC)																	
额定电流 Current per contact	65A / 28A																	
防护等级 Protection	IP67- 插孔插针配合拧紧 When plugged and screwed down																	
温度范围 Temperature range	-20...+130°C																	
测试电压 (两插针之间) Test voltage	4000V / 2500V																	
外壳材料 Housing material	锌合金压铸件 黄铜, 镀镍 Zinc alloy die casting Brass, nickel plating																	
绝缘内嵌体材料 Insulation embedded body material	PA66/PBT, UL 94/V0																	
接触件 (插针) Contact element (male)	<table border="1" style="width: 100%;"> <thead> <tr> <th>类型 Type</th> <th>压线范围 Wire diameter</th> <th>订货号 Part No.</th> </tr> </thead> <tbody> <tr> <td rowspan="2">  Ø2mm </td> <td>1.00-2.50mm²</td> <td>926101</td> </tr> <tr> <td>2.50-4.00mm²</td> <td>926121</td> </tr> <tr> <td rowspan="3">  Ø3.6mm </td> <td>1.50-4.00mm²</td> <td>936141</td> </tr> <tr> <td>6.00mm²</td> <td>936161</td> </tr> <tr> <td>10.00mm²</td> <td>936181</td> </tr> </tbody> </table>			类型 Type	压线范围 Wire diameter	订货号 Part No.	 Ø2mm	1.00-2.50mm ²	926101	2.50-4.00mm ²	926121	 Ø3.6mm	1.50-4.00mm ²	936141	6.00mm ²	936161	10.00mm ²	936181
类型 Type	压线范围 Wire diameter	订货号 Part No.																
 Ø2mm	1.00-2.50mm ²	926101																
	2.50-4.00mm ²	926121																
 Ø3.6mm	1.50-4.00mm ²	936141																
	6.00mm ²	936161																
	10.00mm ²	936181																
订货号 Part No.																		
	1	型号 Form																
备注 Notes																		

M40 圆形电源连接器 CONNECTOR

M40 圆形连接器
Round plug connector M40
现场接线
Field-wireable
3+PE+2-pole
3+PE+4-pole

插针 Male
延长式 Extended type connector



1	No.	940611	940811
型号 Form		RC-M40-PCC-6M-B	RC-M40-PCC-8M-B
极数 Suppression		6p(4 × Ø3.6+2 × Ø2)	8p(4 × Ø3.6+4 × Ø2)

尺寸图 Description

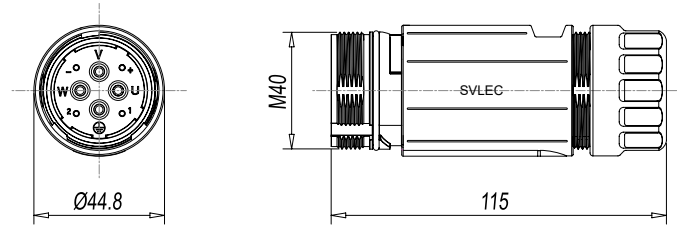

压线范围 Wire diameter 13-28mm

针脚排序 Contact layout

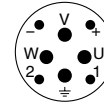
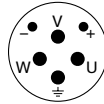

2 技术参数 Technical data

额定电压 Supply voltage	630 V (AC/DC) / 250 V (AC/DC)
额定电流 Current per contact	75A / 30A
防护等级 Protection	IP67- 插孔插针配合拧紧 When plugged and screwed down
温度范围 Temperature range	-20...+130°C
测试电压 (两插针之间) Test voltage	4000V / 2500V
外壳材料 Housing material	锌合金压铸件 黄铜, 镀镍 Zinc alloy die casting Brass, nickel plating
绝缘内嵌体材料 Insulation embedded body material	PA66/PBT, UL 94/V0

接触件 (插针) Contact element (male)



类型 Type	压线范围 Wire diameter	订货号 Part No.
插针 Male Ø2mm	1.00-2.50mm ²	926101
	2.50-4.00mm ²	926121
插针 Male Ø3.6mm	1.50-4.00mm ²	936141
	6.00mm ²	936161
	10.00mm ²	936181

订货号 Part No.

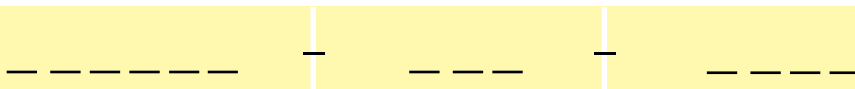

1 型号 Form

备注 Notes

M23 伺服线束 SERVO APPLICATIONS

伺服动力电缆
Servo cable

标准电缆 Servo cable



1	型号 Form	No.	923600	923800	923900
	极数 Suppression		6-pole	8 (3+PE+4)-pole	9 (3+PE+5)-pole

延长电缆 Servo power extension cord



1	型号 Form	No.	923620	923820	923920
	极数 Suppression		6-pole	8 (3+PE+4)-pole	9 (3+PE+5)-pole

2	电缆类型 Cable type	芯数 pole x 标称截面 mm ² Number of cores and mm ² per conductor	高柔性电缆 Highly flexible	固定安装电缆 Fixed installation	外径 O.D
	动力线缆技术参数 Power cable technical data	(4x1.5)C	901	902	9.7
	符合 UL AWM style 20235 CSA	(4x2.5)C	903	904	11.1
	温度范围 Temperature range	(4x4.0)C	905	906	12.9
	挠曲 Flexing : -40°C to +80°C	(4x1.5+(2x1.0))C	911	912	11.1
	静态 Fixed installation : -50°C to +90°C				
	额定电压 Nominal voltage	(4x2.5+(2x0.75))C	913	914	13.6
	UL / CSA 1000V	(4x4.0+(2x1.0))C	915	916	14.2
	VDE				
	动力线 Supply cores : U ₀ / U 600 / 1000V	(4x1.5+2x(2x1.0))C	921	922	12.6
控制线 Control cores : U ₀ / U 300 / 500V					
电缆结构 Design	(4x2.5+2x(2x1.0))C	923	924	14.6	
镀锡铜丝编织屏蔽	(4x4.0+2x(2x1.0))C	925	926	16.0	
Tinned copper screen braiding					
橙色护套 Orange jacket (RAL 2003)					
符合 In according with DESINA®					

3	电缆长度 Cable length	
	1.5m	0150
	3.0m	0300
	5.0m	0500
	7.5m	0750
	10.0m	1000

订货号 Part No.

例: 923600 - 901 - 0500

1 型号 Form **2** 电缆类型 Cable type **3** 电缆长度 Cable length

备注 Notes

电缆参数 Cable parameter: 7.6.6 配件及技术页面 Accessories and technical page: 7.6.4
不同的电缆长度可根据实际需要, 在订货号的第三部分自行修改, 电缆长度单位: cm

M23 伺服线束 SERVO APPLICATIONS

Siemens 标准
6FX5002 / 6 FX8002
系列动力控制电缆
Servo cable



1 型号 Form No. 923609

极数
Suppression 6-pole

Siemens 标准
6FX5002-5DN06-1BF



型号 Form No. 923602

极数
Suppression 6-pole

2 电缆类型 Cable type	芯数 pole x 标称截面 mm ² Number of cores and mm ² per conductor	高柔性电缆 Highly flexible	固定安装电缆 Fixed installation	外径 O.D
动力线缆技术参数 Power cable technical data	(4x1.5)C	901	902	9.7
符合 UL AWM style 20235 CSA	(4x2.5)C	903	904	11.1
温度范围 Temperature range	(4x4.0)C	905	906	12.9
挠曲 Flexing : -40°C to +80°C	(4x1.5+(2x1.0))C	911	912	11.1
静态 Fixed installation : -50°C to +90°C	(4x2.5+(2x0.75))C	913	914	13.6
额定电压 Nominal voltage	(4x4.0+(2x1.0))C	915	916	14.2
UL / CSA 1000V VDE				
动力线 Supply cores : U ₀ / U 600 / 1000V 控制线 Control cores : U ₀ / U 300 / 500V				

3 电缆长度 Cable length

1.5m	0150
3.0m	0300
5.0m	0500
7.5m	0750
10.0m	1000

订货号 Part No.

例: 923609 - 901 - 0500

1 型号 Form **2** 电缆类型 Cable type **3** 电缆长度 Cable length

备注 Notes

电缆参数 Cable parameter: 7.6.6 配件及技术页面 Accessories and technical page: 7.6.4
不同的电缆长度可根据实际需要, 在订货号的第三部分自行修改, 电缆长度单位: cm

M40 伺服线束 SERVO APPLICATIONS

伺服动力标准电缆
Servo cable

标准电缆 Servo cable



1	型号 Form	No.	940400	940600	940800
	极数 Suppression		4-pole	6(4+2)-pole	8(4+2+2)-pole

延长电缆 Servo power extension cord



1	型号 Form	No.	940420	940620	940820
	极数 Suppression		4-pole	6(4+2)-pole	8(4+2+2)-pole

2	电缆类型 Cable type	芯数 pole x 标称截面 mm ² Number of cores and mm ² per conductor	高柔性电缆 Highly flexible	固定安装电缆 Fixed installation	外径 O.D
	动力线缆技术参数 Power cable technical data	(4x1.5)C	901	902	9.7
	符合 UL AWM style 20235 CSA	(4x2.5)C	903	904	11.1
	温度范围 Temperature range	(4x4.0)C	905	906	12.9
	挠曲 Flexing : -40°C to +80°C	(4x6.0)C	907	908	15.2
	静态 Fixed installation : -50°C to +90°C	(4x1.5+(2x1.0))C	911	912	11.1
	额定电压 Nominal voltage	(4x2.5+(2x0.75))C	913	914	13.6
	UL / CSA 1000V	(4x4.0+(2x1.0))C	915	916	14.2
	VDE	(4x6.0+(2x1.0))C	917	918	16.5
	动力线 Supply cores : U ₀ / U 600 / 1000V	(4x1.5+2x(2x1.0))C	921	922	12.6
	控制线 Control cores : U ₀ / U 300 / 500V	(4x2.5+2x(2x1.0))C	923	924	14.6
	电缆结构 Design	(4x4.0+2x(2x1.0))C	925	926	16.0
	镀锡铜丝编织屏蔽 Tinned copper screen braiding	(4x6.0+2x(2x1.0))C	927	928	19.2
橙色护套 Orange jacket (RAL 2003) 符合 In according with DESINA®					

3	电缆长度 Cable length	
	1.5m	0150
	3.0m	0300
	5.0m	0500
	7.5m	0750
	10.0m	1000

订货号 Part No.

例: 940400 - 901 - 0500

1 型号 Form 2 电缆类型 Cable type 3 电缆长度 Cable length

备注 Notes

电缆参数 Cable parameter: 7.6.6 配件及技术页面 Accessories and technical page: 7.6.4
不同的电缆长度可根据实际需要, 在订货号的第三部分自行修改, 电缆长度单位: cm

M40 伺服线束 SERVO APPLICATIONS

系列动力控制电缆
Servo cable



1 型号 Form No. 940609

极数
Suppression

6-pole



型号 Form No. 940602

极数
Suppression

6-pole

2 电缆类型 Cable type	芯数 pole x 标称截面 mm ² Number of cores and mm ² per conductor	高柔性电缆	固定安装电缆	外径 O.D
		Highly flexible	Fixed installation	
动力线缆技术参数 Power cable technical data	(4x1.5)C	901	902	9.7
符合 UL AWM style 20235 CSA	(4x2.5)C	903	904	11.1
温度范围 Temperature range	(4x4.0)C	905	906	12.9
挠曲 Flexing : -40°C to +80°C	(4x6.0)C	907	908	15.2
静态 Fixed installation : -50°C to +90°C	(4x1.5+(2x1.0))C	911	912	11.1
额定电压 Nominal voltage	(4x2.5+(2x0.75))C	913	914	13.6
UL / CSA 1000V	(4x4.0+(2x1.0))C	915	916	14.2
VDE	(4x6.0+(2x1.0))C	917	918	16.5
动力线 Supply cores : U ₀ /U 600 / 1000V				
控制线 Control cores : U ₀ /U 300 / 500V				

3 电缆长度 Cable length

1.5m	0150
3.0m	0300
5.0m	0500
7.5m	0750
10.0m	1000

订货号 Part No.

例: 940609 - 901 - 0500

1 型号 Form **2** 电缆类型 Cable type **3** 电缆长度 Cable length

备注 Notes

电缆参数 Cable parameter: 7.6.6 配件及技术页面 Accessories and technical page: 7.6.4
不同的电缆长度可根据实际需要, 在订货号的第三部分自行修改, 电缆长度单位: cm

M40 伺服线束 SERVO APPLICATIONS

主轴动力电缆
 Spindle power cable



1	连接方式 The connection method	○ 型端带金属接头					
2	电缆类型 Cable type	型号 Form	芯数 pole x 标称截面 mm² Number of cores and mm ² per conductor	金属接头 Cable glands	高柔性电缆 Highly flexible	固定安装电缆 Fixed installation	外径 O.D
	动力线缆技术参数 Power cable technical data 符合 UL AWM style 20235 CSA	942525	(4 x 2.5) C	M25x1.5	903	904	11.1
	温度范围 Temperature range 挠曲 Flexing : -40°C to +80°C 静态 Fixed installation : -50°C to +90°C	942540	(4 x 4.0) C	M25x1.5	905	906	12.9
	额定电压 Nominal voltage UL / CSA 1000V VDE 动力线 Supply cores : U ₀ / U 600 / 1000V 控制线 Control cores : U ₀ / U 300 / 500V	943225	(4 x 2.5) C	M32x1.5	903	904	11.1
	电缆结构 Design 镀锡铜丝编织屏蔽 Tinned copper screen braiding 橙色护套 Orange jacket (RAL 2003) 符合 In according with DESINA®	943240	(4 x 4.0) C	M32x1.5	905	906	12.9
		944060	(4 x 6.0) C	M40x1.5	907	908	15.2
3	电缆长度 Cable length						
	1.5m	0150					
	3.0m	0300					
	5.0m	0500					
	7.5m	0750					
	10.0m	1000					
	订货号 Part No.						
		例: 942525 — 903 — 0500					
		1	型号 Form	2	电缆类型 Cable type	3	电缆长度 Cable length
	备注 Notes						
		电缆参数 Cable parameter: 7.6.6 配件及技术页面 Accessories and technical page: 7.6.4 不同的电缆长度可根据实际需要, 在订货号的第三部分自行修改, 电缆长度单位: cm					

伺服动力电缆

SINAMICS S120 信号电缆

Siemens 标准
6FX5002 / 6 FX8002
系列信号控制电缆
Series of signal control cable
(DRIVE-CLiQ)

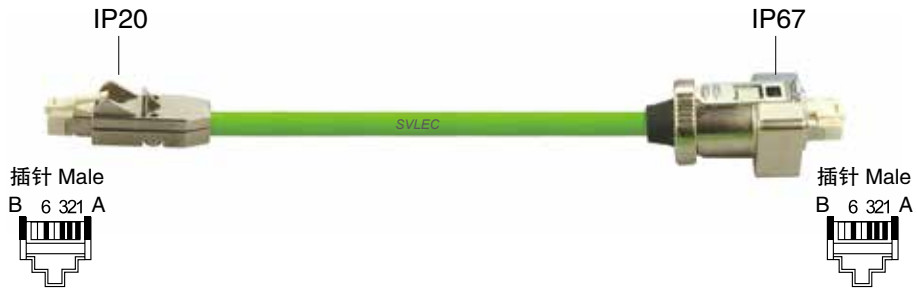

1	型号 Form	No.	IP 20/IP 20	IP 20/IP67	IP 67/IP 67
	两端插头均为金属屏蔽壳体		945101	945121	945161
	极数 Suppression		4(Ethernet)+2(Power)		

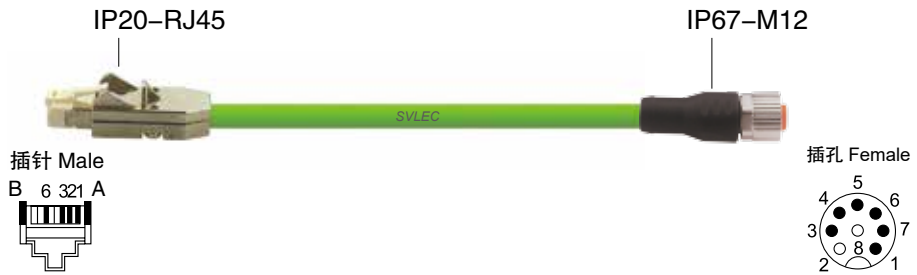

1	型号 Form	No.	IP 20-RJ45/IP67-M12		
			945181		
	极数 Suppression		4(Ethernet)+2(Power)		

2	电缆类型 Cable type	芯数 pole x 标称截面 mm ² Number of cores and mm ² per conductor	电缆 Cable	外径 O.D	应用 Application
		(2 × (2 × 0.2) + 2 × 0.38)C PVC	952	7	西门子 Simodrive
		(2 × (2 × 0.2) + 2 × 0.38)C PUR	932	7	西门子 Simodrive

	连接器可单独订购 The connector can be ordered separately	No.	IP 20	IP 67
	屏蔽外壳 Shielding enclosure		945010	945020

3		
	1.5m	0150
	3.0m	0300
	5.0m	0500
	7.5m	0750
	10.0m	1000

订货号 Part No.

例: 945101 - 952 - 0500

1 型号 Form **2** 电缆类型 Cable type **3** 电缆长度 Cable length

备注 Notes
 电缆参数 Cable parameter: 7.6.6 配件及技术页面 Accessories and technical page: 7.6.4
 不同的电缆长度可根据实际需要, 在订货号的第三部分自行修改, 电缆长度单位: cm

SINAMICS S120 信号电缆

Siemens 标准
6FX5002 / 6 FX8002
系列信号控制电缆
Series of signal control cable
(DRIVE-CLiQ)



1	型号 Form	西门子型号 Siemens type	长度
	945131-795GY-0011	6SL3060-4AB00-0AA0	0.11
	945131-795GY-0016	6SL3060-4AD00-0AA0	0.16
	945131-795GY-0021	6SL3060-4AF00-0AA0	0.21
	945131-795GY-0026	6SL3060-4AH00-0AA0	0.26
	945131-795GY-0031	6SL3060-4AK00-0AA0	0.31
	945131-795GY-0036	6SL3060-4AM00-0AA0	0.36
	945131-795GY-0041	6SL3060-4AP00-0AA0	0.41
	945131-795GY-0060	6SL3060-4AU00-0AA0	0.60
	945131-795GY-0095	6SL3060-4AA10-0AA0	0.95
	945131-795GY-0120	6SL3060-4AW00-0AA0	1.20
	945131-795GY-0145	6SL3060-4AF10-0AA0	1.45
	945131-795GY-0280	6SL3060-4AJ20-0AA0	2.80
	945131-795GY-0500	6SL3060-4AA50-0AA0	5.00

电缆长度可根据实际需要定制!

2	电缆长度 Cable length	
	1.5m	0150
	3.0m	0300
	5.0m	0500
	7.5m	0750
	10.0m	1000

订货号 Part No.

例: 945131 - 795GY - 0500

1 型号 Form **2** 电缆类型 Cable type **3** 电缆长度 Cable length

备注 Notes

电缆参数 Cable parameter: 7.6.6 配件及技术页面 Accessories and technical page: 7.6.4
不同的电缆长度可根据实际需要, 在订货号的第三部分自行修改, 电缆长度单位: cm

M23 伺服线束 SERVO APPLICATIONS

伺服标准信号电缆
The servo signal cable standard

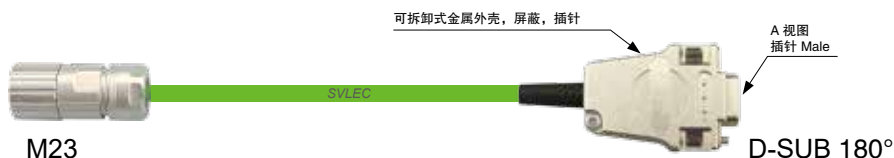

1	型号 Form No.	923149	923147	923279	923276
	极数 Suppression	12-pole / D-SUB 15	12-pole / D-SUB 25	17-pole / D-SUB 15	17-pole / D-SUB 25

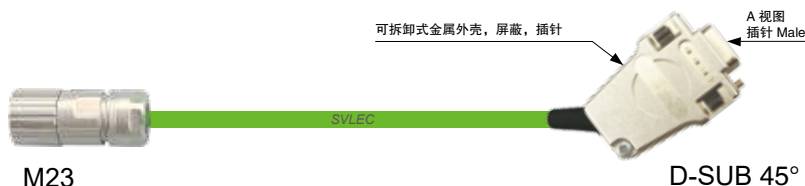

型号 Form No.	923129	923127	923179	923176
极数 Suppression	12-pole / D-SUB 15	12-pole / D-SUB 25	17-pole / D-SUB 15	17-pole / D-SUB 25

M23-M23



型号 Form No.	923919	923120	923170
极数 Suppression	9-pole	12-pole	17-pole

2	电缆类型 Cable type	芯数 pole x 标称截面 mm ² Number of cores and mm ² per conductor	高柔性电缆 Highly flexible	固定安装电缆 Fixed installation	外径 O.D
电缆结构 Design 导体: 裸铜束绞线和镀锡铜丝束符合 IEC 60228 cl.5 和 cl.6, 改良聚丙烯绝缘, 根据颜色识别芯线。 芯线: 部分对绞, 镀锡铜丝编织层 (覆盖率 ≥ 90%) 镀锡铜排绕线, 薄膜包覆, PE 绝缘层; 线对和芯线绞合薄膜包覆 屏蔽层: 镀锡铜丝编织层 (覆盖率 ≥ 85%) 技术参数 Technical data 额定电压 Nominal voltage: 30V 测试电压 The test voltage: 500V	(2x0.38+3x2x0.22)C	508	/	7.5	
	(2x0.38+4x2x0.22)C	510	/	7.5	
	(2x0.38+5x2x0.22)C	512	/	7.5	
	(4x0.75+(5x0.15)+2x4x0.15)C	716	/	8.9	
	(4x2x0.18)C	930	931	6.4	
	(3x(2x0.14)+(4x0.14)+(4x0.22)+(2x0.5))C	942	939	10.2	
	(4x(2x0.34)+4x0.5)C	944	941	9.6	
	(12x0.22)C	946	945	7.2	
	(4x2x0.14+4x0.5)C	948	955	8.1	
	(3x2x0.25+2x0.5)C	950	958	7.5	
	(10x0.14+2x0.5)C	956	959	7.2	

3	电缆长度 Cable length	
	1.5m	0150
	3.0m	0300
	5.0m	0500
	7.5m	0750
	10.0m	1000

订货号 Part No.

例: 923149 508 0500

1 型号 Form **2** 电缆类型 Cable type **3** 电缆长度 Cable length

备注 Notes

电缆参数 Cable parameter: 7.6.6 配件及技术页面 Accessories and technical page: 7.6.4
不同的电缆长度可根据实际需要, 在订货号的第三部分自行修改, 电缆长度单位: cm

M23 伺服线束 SERVO APPLICATIONS

伺服标准信号电缆
Servo signal cable standard

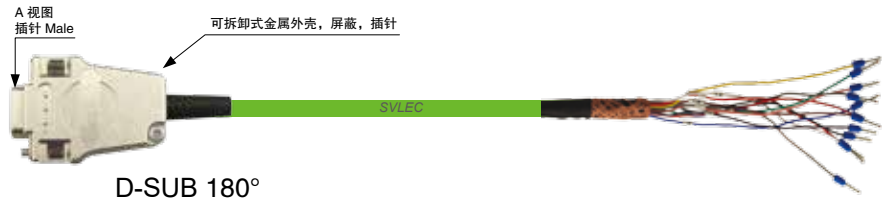

1	型号 Form	No.	990009	990015	990025
	极数		D-SUB 9	D-SUB 15	D-SUB 25
	Suppression				

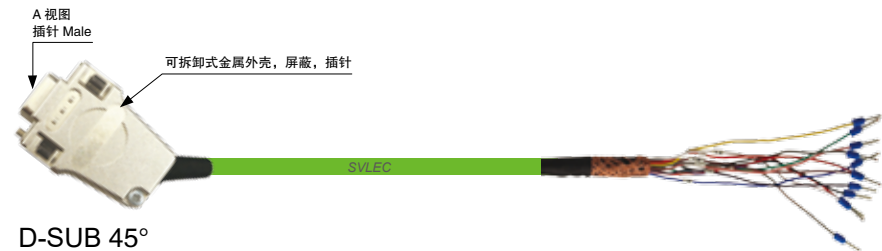

	型号 Form	No.	990109	990115	990125
	极数		D-SUB 9	D-SUB 15	D-SUB 25
	Suppression				

2	电缆类型 Cable type	芯数 pole x 标称截面 mm² Number of cores and mm ² per conductor	高柔性电缆 Highly flexible	固定安装电缆 Fixed installation	外径 O.D
	电缆结构 Design	(2x0.38+3x2x0.22)C	508	/	7.5
	导体 : 裸铜束绞线和镀锡铜丝束符合 IEC 60228 cl.5 和 cl.6, 改良聚丙烯绝缘, 根据颜色识别芯线。	(2x0.38+4x2x0.22)C	510	/	7.5
		(2x0.38+5x2x0.22)C	512	/	7.5
	芯线 : 部分对绞, 镀锡铜丝编织层 (覆盖率 ≥ 90%) 镀锡铜排绕线, 薄膜包覆, PE 绝缘层; 线对和芯线绞合薄膜包覆	(4x0.75+(5x0.15)+2x4x0.15)C	716	/	8.9
		(4x2x0.18)C	930	931	6.4
		(3x(2x0.14)+(4x0.14)+(4x0.22)+(2x0.5))C	942	939	10.2
		(4x(2x0.34)+4x0.5)C	944	941	9.6
	屏蔽层 : 镀锡铜丝编织层 (覆盖率 ≥ 85%)	(12x0.22)C	946	945	7.2
		(4x2x0.14+4x0.5)C	948	955	8.1
	技术参数 Technical data	(3x2x0.25+2x0.5)C	950	958	7.5
	额定电压 Nominal voltage : 30V	(10x0.14+2x0.5)C	956	959	7.2
	测试电压 The test voltage : 500V				

3	电缆长度 Cable length	
	1.5m	0150
	3.0m	0300
	5.0m	0500
	7.5m	0750
	10.0m	1000

订货号 Part No.

例: 990009 - 508 - 0500

1 型号 Form **2** 电缆类型 Cable type **3** 电缆长度 Cable length

备注 Notes

电缆参数 Cable parameter: 7.6.6 配件及技术页面 Accessories and technical page: 7.6.4
不同的电缆长度可根据实际需要, 在订货号的第三部分自行修改, 电缆长度单位: cm

伺服线束 SERVO APPLICATIONS

Siemens V90

6FX3002 系列

动力控制电缆

Servo harnessing according



1	芯数 pole x 标称截面 mm ² Number of cores and mm ² per conductor	型号 Form	固定安装电缆 Fixed installation	高柔性电缆 Highly flexible	外径 O.D	西门子型号 Siemens type	轴高
	(4x0.75)C	904001	407	417	7.0	6FX3002-5CK01-XXXX	低惯量, 轴高 (20-40mm)



	芯数 pole x 标称截面 mm ² Number of cores and mm ² per conductor	型号 Form	固定安装电缆 Fixed installation	高柔性电缆 Highly flexible	外径 O.D	西门子型号 Siemens type	轴高
	(4x2.5)C	904002	904	903	11.1	6FX3002-5CK31-XXXX	低惯量, 轴高 (50mm)
	(4x1.5)C	904002	902	901	9.7	6FX3002-5CL01-XXXX	高惯量, 轴高 (45-90mm)
	(4x2.5)C	904003	904	903	11.1	6FX3002-5CL11-XXXX	



	芯数 pole x 标称截面 mm ² Number of cores and mm ² per conductor	型号 Form	固定安装电缆 Fixed installation	高柔性电缆 Highly flexible	外径 O.D	西门子型号 Siemens type	轴高
	(4x2.5)C	904002N	904	903	11.1	6FX3002-5CK32-XXXX	低惯量, 轴高 (50mm)
	(4x1.5)C	904002N	902	901	9.7	6FX3002-5CL02-XXXX	高惯量, 轴高 (45-90mm)
	(4x2.5)C	904003N	904	903	11.1	6FX3002-5CL12-XXXX	

电缆长度 Cable length

1.5m	0150
3.0m	0300
5.0m	0500
7.5m	0750
10.0m	1000

订货号 Part No.

例: 904001 - 407 - 0500

1 型号 Form **2** 电缆类型 Cable type **3** 电缆长度 Cable length

备注 Notes

电缆参数 Cable parameter: 7.6.6 配件及技术页面 Accessories and technical page: 7.6.4
不同的电缆长度可根据实际需要, 在订货号的第三部分自行修改, 电缆长度单位: cm

伺服线束 SERVO APPLICATIONS

Siemens V90
 6FX3002 系列
 编码器线缆
 The encoder cables



1	芯数 pole x 标称截面 mm ² Number of cores and mm ² per conductor	型号 Form	固定安装电缆 Fixed installation	高柔性电缆 Highly flexible	外径 O.D	西门子型号 Siemens type	轴高
	(3x(2x0.22)+2x2x0.25)C	904010	102	112	7.0	6FX3002-2CT20-XXXX	低惯量 (20-40mm) 增量式编码器
	(3x(2x0.22)+2x2x0.25)C	904040	102	112	7.0	6FX3002-2DB20-XXXX	低惯量 (20-40mm) 绝对值编码器
	(3x(2x0.22)+2x2x0.25)C	904020N	102	112	7.0	6FX3002-2CT12-XXXX	低惯量 (50mm) / 高惯量 增量式编码器
	(3x(2x0.22)+2x2x0.25)C	904030N	102	112	7.0	6FX3002-2DB12-XXXX	低惯量 (50mm) 绝对值编码器
	(3x(2x0.22)+2x2x0.25)C	904020	102	112	7.0	6FX3002-2CT10-XXXX	低惯量 (50mm) / 高惯量 增量式编码器
	(3x(2x0.22)+2x2x0.25)C	904030	102	112	7.0	6FX3002-2DB10-XXXX	高惯量 (45-90mm) 绝对值编码器
电缆长度 Cable length							
	1.5m	0150					
	3.0m	0300					
	5.0m	0500					
	7.5m	0750					
	10.0m	1000					
订货号 Part No.							
例: <u> 904010 </u> <u> 102 </u> <u> 0500 </u>							
1 型号 Form			2 电缆类型 Cable type			3 电缆长度 Cable length	
备注 Notes							
电缆参数 Cable parameter: 7.6.6 配件及技术页面 Accessories and technical page: 7.6.4 不同的电缆长度可根据实际需要, 在订货号的第三部分自行修改, 电缆长度单位: cm							

伺服线束 SERVO APPLICATIONS

Siemens V90
6FX3002 系列
抱闸电缆
Brake cable



1	芯数 pole x 标称截面 mm ² Number of cores and mm ² per conductor	型号 Form	固定安装电缆 Fixed installation	高柔性电缆 Highly flexible	外径 O.D	西门子型号 Siemens type	轴高
	(2x0.75)C	904004	207	267	6.0	6FX3002-5BK02-XXXX	低惯量, 轴高 (20-40mm)



	芯数 pole x 标称截面 mm ² Number of cores and mm ² per conductor	型号 Form	固定安装电缆 Fixed installation	高柔性电缆 Highly flexible	外径 O.D	西门子型号 Siemens type	轴高
	(2x0.75)C	904005	207	267	6.0	6FX3002-5BL02-XXXX	低惯量 (50mm) 高惯量 (45-90mm)



	芯数 pole x 标称截面 mm ² Number of cores and mm ² per conductor	型号 Form	固定安装电缆 Fixed installation	高柔性电缆 Highly flexible	外径 O.D	西门子型号 Siemens type	轴高
	(2x0.75)C	904005N	207	267	6.0	6FX3002-5BL03-XXXX	低惯量 (50mm) 高惯量 (45-90mm)



	芯数 pole x 标称截面 mm ² Number of cores and mm ² per conductor	高柔性电缆 Highly flexible	西门子型号 Siemens type	数据线
	12 x 0.14mm ²	706	6SL3260-4MA00-XXXX	20 芯 I/O 电缆
	50 x 0.08mm ²	550	6SL3260-4NA00-XXXX	50 芯设定值电缆

电缆长度 Cable length	
1.5m	0150
3.0m	0300
5.0m	0500
7.5m	0750
10.0m	1000

订货号 Part No.

例: 904004 - 207 - 0500

1 型号 Form **2** 电缆类型 Cable type **3** 电缆长度 Cable length

备注 Notes

电缆参数 Cable parameter: 7.6.6 配件及技术页面 Accessories and technical page: 7.6.4
不同的电缆长度可根据实际需要, 在订货号的第三部分自行修改, 电缆长度单位: cm

连接器附件 ACCESORIES

配件 Accessories	型号 Type	订货号 Part No.	
	V90 控制电缆 14 芯连接器, 驱动侧 6FX2003-0SB14	990014	
	V90 控制电缆 20 芯连接器, 驱动侧 6SL3260-2MA00-0VA0	990021	
	V90 控制电缆 50 芯连接器, 驱动侧 6SL3260-2NA00-0VA0	990051	
	V90 控制电缆 12 芯连接器, 电机侧 6FX2003-0SL12	990012	
	V90 动力 4 芯连接器, 电机侧 (含针) 6FX2003-0LL13	923401T	
	Ø2 mm 插孔 Female 1.00 - 2.50 mm ²	926201	
	V90 抱闸 2 芯连接器, 电机侧 (含针) 6FX2003-0LL53	917202T	
	V90 增量编码器 8 芯连接器 (3 个卡槽), 电机侧 (含针) 6FX2003-0SL13	917803T	
	Ø1 mm 插孔 Female 0.14 - 1.00 mm ²	916221	
	驱动器侧插头 (动力) 西门子 Drive side plug (power) of Siemens	999148	
	伺服插头公针 Male		
	线径 Wire	1.5mm ² CPM - 1.5	999148-15
	2.5mm ² CPM - 2.5	999148-25	
	4.0mm ² CPM - 4.0	999148-40	
	6.0mm ² CPM - 6.0	999148-60	

连接器附件 ACCESORIES

名称 Designation		型号 Form	订货号 Part No.
	带有适用于 C/D 型电机模块的螺钉式接线端子的电源连接器	6SL3162-2MA00-0ACO	963162
	驱动器侧插头 (编码器) 西门子 IP20 Drive side plug (encoder) of Siemens		945010
	驱动器侧插头 (编码器) 西门子 IP65 Drive side plug (encoder) of Siemens		945020
保护盖 Blind plug 	M23 信号插孔保护盖 (金属) The signal jack protection cover (metal)	RC-S-PMC	996030
保护盖 Blind plug 	M23 信号插针保护盖 (塑料) The signal pin protection cover (plastic)	RC-S-BPC	996010
	M23 动力插针保护盖 (塑料) Power pin protection cover (plastic)	RC-P-BPC	996110
保护盖 Blind plug 	M23 信号插针保护盖 (金属) The signal pin protection cover (metal)	RC-S-BMC	996020
安装环 Install the ring 	M23 信号安装环 Signal installation ring	RC-S-M	999231
	M23 动力安装环 Power installation ring	RC-P-M	999232
工具 Tool			
	信号插针压线钳 The signal pin wire clamp	CPT-S	999991
	M23 动力插针压线钳 Power pin pressing line clamp	CPT-P	999992
	M40 动力插针压线钳 Power pin pressing line clamp	CRIMVBOX-6.0/10.0	600001002

电缆技术参数 TECHNICAL PARAMETERS FOR CABLES



伺服 servo	导线直径 wires diameter	拖链安装 Suitable for C-track	护套 Jacket	外径 mm Outer-Ø	弯曲半径 Bend radius mobile	温度范围 Temperature range	
						静态 Fixed °C	动态 Mobile °C
407	(4×0.75)C	不适合 No	PVC	approx. 7.0			
417	(4×0.75)C	适合 Yes	PUR	approx. 7.0			
901	(4×1.5)C	适合 Yes	PUR	approx. 9.7	10 × outer-Ø	-50...+90	-40...+80
902	(4×1.5)C	不适合 No	PVC	approx. 9.7	10 × outer-Ø	-50...+90	-40...+80
903	(4×2.5)C	适合 Yes	PUR	approx. 11.1	10 × outer-Ø	-50...+90	-40...+80
904	(4×2.5)C	不适合 No	PVC	approx. 11.1	10 × outer-Ø	-50...+90	-40...+80
905	(4×4.0)C	适合 Yes	PUR	approx. 12.9	10 × outer-Ø	-50...+90	-40...+80
906	(4×4.0)C	不适合 No	PVC	approx. 12.9	10 × outer-Ø	-50...+90	-40...+80
907	(4×6.0)C	适合 Yes	PUR	approx. 12.9	10 × outer-Ø	-50...+90	-40...+80
908	(4×6.0)C	不适合 No	PVC	approx. 12.9	10 × outer-Ø	-50...+90	-40...+80
911	(4×1.5+(2×1.0))C	适合 Yes	PUR	approx. 11.1	10 × outer-Ø	-50...+90	-40...+80
912	(4×1.5+(2×1.0))C	不适合 No	PVC	approx. 11.1	10 × outer-Ø	-50...+90	-40...+80
913	(4×2.5+(2×1.0))C	适合 Yes	PUR	approx. 13.6	10 × outer-Ø	-50...+90	-40...+80
914	(4×2.5+(2×0.75))C	不适合 No	PVC	approx. 13.6	10 × outer-Ø	-50...+90	-40...+80
915	(4×4.0+(2×1.0))C	适合 Yes	PUR	approx. 14.2	10 × outer-Ø	-50...+90	-40...+80
916	(4×4.0+(2×1.0))C	不适合 No	PVC	approx. 14.2	10 × outer-Ø	-50...+90	-40...+80
917	(4×6.0+(2×1.0))C	适合 Yes	PUR	approx. 16.5	10 × outer-Ø	-50...+90	-40...+80
918	(4×6.0+(2×1.0))C	不适合 No	PVC	approx. 16.5	10 × outer-Ø	-50...+90	-40...+80
921	(4×1.5+2×(2×1.0))C	适合 Yes	PUR	approx. 12.6	10 × outer-Ø	-50...+90	-40...+80
922	(4×1.5+2×(2×1.0))C	不适合 No	PVC	approx. 12.6	10 × outer-Ø	-50...+90	-40...+80
923	(4×2.5+2×(2×1.0))C	适合 Yes	PUR	approx. 14.6	10 × outer-Ø	-50...+90	-40...+80
924	(4×2.5+2×(2×1.0))C	不适合 No	PVC	approx. 14.6	10 × outer-Ø	-50...+90	-40...+80
925	(4×4.0+2×(2×1.0))C	适合 Yes	PUR	approx. 16.0	10 × outer-Ø	-50...+90	-40...+80
926	(4×4.0+2×(2×1.0))C	不适合 No	PVC	approx. 16.0	10 × outer-Ø	-50...+90	-40...+80
927	(4×6.0+2×(2×1.0))C	适合 Yes	PUR	approx. 19.2	10 × outer-Ø	-50...+90	-40...+80
928	(4×6.0+2×(2×1.0))C	不适合 No	PVC	approx. 19.2	10 × outer-Ø	-50...+90	-40...+80
930	(4×2×0.18)C	适合 Yes	PUR	approx.6.4	10 × outer-Ø	-40...+85	-40...+80
931	(4×2×0.18)C	不适合 No	PVC	approx.6.4	10 × outer-Ø	-40...+85	-40...+80
932	(2×(2×0.2)+2×0.38)C	适合 Yes	PUR	approx.7.0	10 × outer-Ø	-40...+85	-40...+80
939	(3×(2×0.14)+(4×0.14)+(4×0.22)+(2×0.5))C	不适合 No	PVC	approx.10.2	10 × outer-Ø	-40...+85	-40...+80
941	(4×(2×0.34)+4×0.5)C	不适合 No	PVC	approx.9.6	10 × outer-Ø	-40...+85	-40...+80
942	(3×(2×0.14)+(4×0.14)+(4×0.22)+(2×0.5))C	适合 Yes	PUR	approx.10.2	10 × outer-Ø	-40...+85	-40...+80
944	(4×(2×0.34)+4×0.5)C	适合 Yes	PUR	approx.9.6	10 × outer-Ø	-40...+85	-40...+80
945	(12×0.22)C	不适合 No	PVC	approx.7.2	10 × outer-Ø	-40...+85	-40...+80
946	(12×0.22)C	适合 Yes	PUR	approx.7.2	10 × outer-Ø	-40...+85	-40...+80
948	(4×2×0.14+4×0.5)C	适合 Yes	PUR	approx.8.1	10 × outer-Ø	-40...+85	-40...+80
950	(3×2×0.25+2×0.5)C	适合 Yes	PUR	approx.7.5	10 × outer-Ø	-40...+85	-40...+80
952	(2×(2×0.2)+2×0.38)C	不适合 No	PVC	approx.7.0	10 × outer-Ø	-40...+85	-40...+80
955	(4×2×0.14+4×0.5)C	不适合 No	PVC	approx.7.2	10 × outer-Ø	-40...+85	-40...+80
956	(10×0.14+2×0.5)C	适合 Yes	PUR	approx.8.1	10 × outer-Ø	-40...+85	-40...+80
958	(3×2×0.25+2×0.5)C	不适合 No	PVC	approx.7.5	10 × outer-Ø	-40...+85	-40...+80
959	(10×0.14+2×0.5)C	不适合 No	PVC	approx.7.2	10 × outer-Ø	-40...+85	-40...+80
102	(3×(2×0.22)+2×2×0.25)C	不适合 No	PVC	approx.7.0	10 × outer-Ø	-40...+85	-40...+80
112	(3×(2×0.22)+2×2×0.25)C	适合 Yes	PUR	approx. 7.0	10 × outer-Ø	-40...+85	-40...+80
508	1P×0.38+3P×0.22	适合 Yes	PUR	approx. 7.5	10 × outer-Ø	-40...+85	-40...+80
510	1P×0.38+4P×0.22	适合 Yes	PUR	approx. 7.5	10 × outer-Ø	-40...+85	-40...+80
512	1P×0.38+5P×0.22	适合 Yes	PUR	approx. 7.5	10 × outer-Ø	-40...+85	-40...+80
716	4×0.75+(4×0.15)+2×4×0.15	不适合 No	PUR	approx. 8.9	10 × outer-Ø	-40...+85	-40...+80
207	(2×0.75)C	不适合 No	PVC	approx. 6.0	10 × outer-Ø	-40...+85	-40...+80
267	(2×0.75)C	适合 Yes	PUR	approx. 6.0	10 × outer-Ø	-40...+85	-40...+80
550	50 x 28AWG					-40...+105	-40...+80